



Interdisciplinary Doctoral School
Doctoral research field: MEDICINE

Ph.D. Thesis - Summary

**RESEARCHES ON THROMBOTIC AND
HEMORRHAGIC COMPLICATIONS OF
PATIENTS WITH CHRONIC LIVER
DISEASES IN SOUTHERN TRANSYLVANIA**

Ph.D. Candidate:
LILIANA NOVAC (married VECERZAN)

Ph.D. Advisor:
Prof. univ. dr. ROMEO GABRIEL MIHĂILĂ

CONTENTS



Motivation for choosing the theme	7
INTRODUCTION	8
PART I. FRAMEWORK PRESENTATION RESEARCH. CURRENT STATE OF KNOWLEDGE.....	10
I.1. COAGULATION DISORDERS IN CHRONIC LIVER DISEASES	11
I.1.1. General data	11
I.1.2. Hemostatic system in chronic liver diseases	12
I.1.3. Coagulation.....	14
I.1.4. Platelets.....	15
I.1.5. Fibrinolysis	16
I.2. PROCOAGULATING IMBALANCE IN CHRONIC LIVER DISEASES.....	18
I.2.1. General characteristics.....	18
I.2.2. Clinical implications of procoagulant imbalance	19
I.2.3. Liver fibrosis.....	22
I. 3. CORRELATION BETWEEN PROTHROMBOTIC STATUS AND LIVER FIBROGENESIS	24
I.3.1. General data	24
I.3.2. Overview of the coagulation cascade and fibrinolysis	25
I.3.3. Coagulation signalling: proteinase-activated receptors	26
I.3.4. Coagulation and liver fibrosis.....	27
I.3.5. The pro-fibrogenic role of activated thrombin-stimulated liver cells.....	29
I.3.6. Thrombin induction of connective tissue growth factor and the effects of factor Xa ..	30
I.3.7. Prothrombotic factors and association with liver fibrosis	31
I.3.8. Anticoagulant therapy, a potential strategy in liver fibrosis.....	33
I.3.9. Microthrombi from intrahepatic vessels - possible causes of fibrosis and tissue ischemia	35
I.4. THROMBOTIC AND HAEMORRHAGIC COMPLICATIONS IN PATIENTS WITH CHRONIC LIVER DISEASES	36
I.4.1. General notions	36
I.4.2. Spontaneous bleeding	37
I.4.2.1. Gastrointestinal bleeding.....	37
I.4.2.2. Intracerebral bleeding.....	39
I.4.3. Bleeding related to invasive procedures	39

I.4.3.1. Liver biopsy.....	39
I.4.3.2. Paracentesis	40
I.4.4.Thrombosis in chronic liver diseases.....	40
I.4.4.1. Portal vein thrombosis.....	41
I.4.4.2. Arterial thrombosis.....	42
I.4.4.3. Peripheral venous thrombosis	43
PART II. PERSONAL CONTRIBUTIONS	45
GENERAL OBJECTIVES OF THE RESEARCH.....	46
GENERAL RESEARCH METHODOLOGY	46
STATISTICAL ANALYSIS.....	48
ETHICAL CONSIDERATIONS.....	49
II. Study no. 1. THROMBIN GENERATION IN CHRONIC LIVER DISEASES - PILOT STUDY	50
II.1.1 Introduction	50
II.1.2. Material and method.....	52
II.1.3. Rezultate.....	54
II.1.4. Discussions.....	62
II.1.5. Conclusions	66
II.Study no. 2. STUDY OF THE CORRELATION BETWEEN THROMBIN GENERATION AND COMPLETE BLOOD COUNT, CLASSICAL EXPLORING COAGULATION AND BIOCHEMICAL TESTS	68
II.2.1. The current state of knowledge	69
II. 2.2. Material and method.....	70
II.2.3. Results	71
II.2.4. Discussions.....	85
II.2.5. Conclusions	90
II.Study no. 3. STUDY OF THE CORRELATION BETWEEN THROMBIN GENERATION AND LIVER FIBROSIS	92
II.3.1. The current state of knowledge	92
II.3.2.Material and method.....	93
II.3.3. Results	98
II.3.4. Discussions.....	116
II.3.5. Conclusions	122
II.Study no. 4. RISK FACTORS REGARDING THROMBOTIC AND BLEEDING COMPLICATIONS IN CHRONIC LIVER DISEASES	124
II.4.1. The current state of knowledge	124
II.4.2. Material and method	123
II.4.3. Results	126
II.4.4. Discussions.....	141

II.4.5. Conclusions	145
The thesis is original by the following achievements.....	147
GENERAL CONCLUSIONS	148
BIBLIOGRAPHY	152
ANNEXES.....	175
LIST OF ABBREVIATIONS.....	175
List of Tables	177
List of images.....	179
Ethics Committee Approval.....	182
List of publications	183



Motivation for choosing the theme

Increasing investigations in patients with chronic liver disease have made it possible to diagnose their complications as early as possible.

It has been observed that some thrombotic and hemorrhagic complications are dependent on the clinical form of chronic liver disease, and most are directly related to the degree of impaired liver function. The correct recognition and interpretation of clinical and paraclinical evidence suggesting liver dysfunction contribute to appropriate therapeutic decisions. Knowledge of these changes is useful both in internal medicine, in the diagnosis of complications, and in practitioners who treat patients with liver disease.

Chronic liver disease is one of the pathologies we frequently encounter in practice and is associated with high rates of morbidity and mortality, especially among the active population. Advanced liver disease is a challenge for the gastroenterologist and internist, being a complex pathology, with progressive, unfavourable evolution, to irreversible liver failure and death, in front of which we often witness helplessness in the absence of liver transplantation.

The originality of the study lies in the assessment of imbalances in the mechanisms of coagulation and hemostasis in patients with chronic liver disease, detected by measuring thrombin formation in plasma poor in platelets. We correlated the results obtained by analyzing thrombin generation parameters in patients with chronic liver disease with ultrasound signs of portal hypertension and liver stiffness, measured with Fibroscan, and demonstrated the mechanism by which prothrombotic status in chronic liver disease promotes liver fibrogenesis. Regarding the results, we believe that our study will be useful for medical practice and for a better understanding of the risk factors involved in the occurrence of thrombohemorrhagic complications in patients with chronic liver disease.

PART I
FRAMEWORK PRESENTATION
RESEARCH.
CURRENT STATE OF KNOWLEDGE

I.1. COAGULATION DISORDERS IN CHRONIC LIVER DISEASES

I.1.1. General data

The liver is the predominant site for the synthesis of multiple coagulation factors, although factor VIII is also synthesized extrahepatically. All pro- and antifibrinolytic proteins are synthesized in the liver by both liver cells and endothelial cells, with subsequent fibrinolysis damage. In chronic liver diseases, both the synthesis of procoagulant factors (fibrinogen, factors VI, VII, IX, X, XI, XII, V, VIII), the procoagulant inhibitors (PAI-1 (plasminogen activator inhibitor-1), α 2-antiplasmin) and the synthesis of anticoagulant factors: antithrombin, protein C, protein S, tissue factor pathway inhibitor (TFPI), and plasminogen are reduced [1,160,212].

The three major anticoagulant proteins - protein C, protein S and antithrombin - have a low level in liver cirrhosis, both by decreasing the synthesis and by increasing consumption. If the thrombotic stimulus is strong, thrombin will form despite the low level of procoagulant proteins [1,8,160,212]. Both prothrombin and antithrombin are low in liver diseases, but the plasma concentration of prothrombin is higher and its activation can lead to rapid consumption of the remaining antithrombin [8,167]. The balance between haemorrhage and thrombosis becomes precarious as the capacity for protein synthesis is lost, with the paradoxical tendency of both phenomena, haemorrhage and thrombosis, to occur in liver failure [1,8,160,163,212].

I.1.3 Coagulation

Regarding end-stage liver disease, another problem is that prothrombin time, expressed as the International Standard Report (INR), is widely used as a prognostic index to calculate the MELD score, which is used to give priority to patients proposed for liver transplantation. However, INR and prothrombin time were used to monitor patients receiving anticoagulant therapy with vitamin K antagonists (warfarin or acenocoumarol). INR cannot be used in patients with chronic liver disease outside of a standardization system.

I.1.4 Platelets

Under normal conditions, platelets have a dual function. They adhere to the walls of damaged vessels through an interaction with the adhesive multimeric protein of von Willebrand factor, thus promoting the adhesion and, finally, the formation of the primary hemostatic plug. Platelets also support the generation of thrombin by assembling activated clotting factors on their surfaces. Thrombocytopenia, a typical feature of chronic liver disease, may be another cause of bleeding.

I.1.5 Fibrinolysis

Fibrinolysis is the set of reactions that gradually leads to enzymatic lysis of the fibrin thrombus, with the repermeabilization of the damaged vessel and the resumption of circulation. The enzymatic key to this process is a blood protein called plasmin, which is formed from a precursor - the circulating, inactive plasminogen (profibrinolysin).

I.2. PROCOAGULANT IMBALANCE IN CHRONIC LIVER DISEASES

I.2.1 General characteristics

In general, the above observations do not suggest that patients with chronic liver disease are naturally 'self-anticoagulated', as previously thought. This concept is reinforced by clinical evidence that these patients are unprotected and may be at increased risk of thrombosis, especially in the portal venous system, especially in the presence of inherited prothrombotic mutations [129].

Laboratory signs of a procoagulant imbalance were not found in previous studies [129,162], but were reported in association with chronic liver disease [22,138]. As mentioned above, thrombin generation in vivo and in vitro has been regulated by thrombomodulin, which effectively slows thrombin generation when plasma is added to healthy subjects, but is less effective when added to plasma in patients with chronic liver disease. This indicates that in such cases the patient's plasma is partially resistant to thrombomodulin-mediated anticoagulation.

I.2.2 Clinical implications of procoagulant imbalance

Patients with cirrhosis of the liver under the age of 45 are at higher risk of developing venous thromboembolism than those without liver disease and prophylactic treatment for venous thromboembolism should be considered [75,158]. Deep vein thrombosis and pulmonary embolism occur in cirrhotic patients with an incidence reported by various authors between 0.5% and 2.7% [155,157]. There is also a high incidence of inherited thrombophilic defects in cirrhotic patients. A thrombophilic genotype is detected by some authors in 69.5% of cirrhotic patients with portal vein thrombosis [129].

Occult thrombotic phenomena may contribute to the progression of stable liver disease to decompensated liver atrophy and pulmonary microthrombosis, with the appearance of porto-pulmonary hypertension [138].

I.2.3 Liver fibrosis

Another consequence of procoagulant imbalance in chronic liver disease is liver fibrosis and its progression. Currently, two hypotheses are involved in the pathogenesis of this condition. Both involve coagulation, and these could be synergistic. One hypothesis is focused on the role of microemboli. Obstructive lesions in the portal vein and hepatic veins occur frequently in patients with liver cirrhosis, due to the formation of microthrombi leading to tissue ischemia, cell death and fibrosis by parenchymal extension [23,64, 92].

I. 3. I. 3. CORRELATION BETWEEN PROTHROMBOTIC STATUS AND LIVER FIBROGENESIS

I.3.1 General data

In the mechanism of liver tissue repair, stellate liver cells (CHS) are recruited at the site of the lesion, and the changes they undergo reflect the paracrin stimulation of all types of cells (sinus endothelial cells, Kupffer cells, hepatocytes, platelets and leukocytes). Thrombin converts circulating fibrinogen into fibrin. It helps platelet aggregation, it is a powerful

activator of endothelial cells, it acts as a chemotransmitter for inflammatory cells and it is a mitogen and chemotransmitter for fibroblasts and vascular smooth muscle cells. Most cellular effects were caused by thrombin and are mediated by a family of G protein-coupled receptors called protease-activated receptors (PARs). All known members of the PAR family stimulate the proliferation / activation of CHS cells [23].

Thrombin receptors are constitutively expressed in the liver, and their expression increases in parallel with the severity and / or duration of hepatopathy. In humans, studies have been performed on thrombotic risk factors, and these have been independently associated with the spread of fibrosis. Some studies have shown that anticoagulants or antiplatelet agents prevent liver necrosis and fibrosis through their action on CHS. These drugs could be considered as therapeutic agents in patients with chronic liver disease and specific studies should be initiated.

Hepatic fibrogenesis is a dynamic process involving complex cellular and molecular mechanisms. CHS changes reflect paracrine stimulation by all neighboring cell types, including sinusoidal endothelium, Kupffer cells, hepatocytes, platelets, and leukocytes. [63]

Platelets are the first cells recruited at the site of injury. They play a key role in healing them, as they limit blood loss by forming aggregates on damaged blood vessels and act as a platform for fibrinogen formation.

I.3.2 Overview of coagulation cascade and fibrinolysis

Extrinsic coagulation is initiated immediately after tissue injury. The extravascular tissue factor (TF), which is normally expressed in the tissue and hidden in the plasma, becomes exposed, initiating the formation of the TF VIIa (FVIIa) complex by binding a small amount of circulating FVIIa. It catalyzes the activation of factor X (FX) in FXa. The TF-FVIIa-FXa complex, in combination with activated factor V (FVa), catalyzes the conversion of prothrombin to thrombin, which in turn converts fibrinogen to fibrin, initiating the formation of a thrombus. Explosive amplification of coagulation is subsequently accomplished by an intrinsic coagulation mechanism. Here, thrombin catalyzes the activation of factors XI, IX, VIII, X.

I.3.4 Coagulation and hepatic fibrosis

Compared to idiopathic pulmonary fibrosis, where the aetiology of the lesion is unknown, the nature of the lesions leading to hepatocyte damage and hepatic fibrosis is much

better defined; this includes hepatitis B or C virus, aberrant lipid metabolism induced by prolonged alcohol consumption or obesity. Injury to hepatocytes or epithelial cells of the intrahepatic bile ducts results from overregulation of inflammation and activation of local mesenchymal populations, stellate liver cells, and periportal fibroblasts. Once activated, both cell types differentiate into contractile myofibroblasts, capable of maintaining the expression of proinflammatory and profibrotic mediators and the storage of the extracellular matrix.

Hepatocytes are the major cellular source of Vitamin K, required for gamma carboxylation, for the synthesis of Vitamin K-dependent coagulation factors, including factors II, V, VII, IX and XI [146, 191]. Loss of hepatocytes due to injury, for example in severe liver cirrhosis, leads to a systemic deficiency of these factors, causing hypocoagulation commonly described in liver diseases [150,164]

I.3.5 The pro-fibrogenic role of activated thrombin-stimulated liver cells

Thrombin is the major effector protease of the coagulation cascade. Thrombin generation is triggered when vascular integrity is disrupted and this allows the activation of plasma coagulation factors by exposing the factor to extravascular tissue. Thrombin converts circulating fibrinogen to fibrin monomer, which polymerizes to the form of fibrin, the fibrous matrix of thrombi [159]. Thrombin also works by promoting platelet aggregation, and by providing positive feedback on a number of coagulation factors to be converted to their active forms. It is a potent activator of endothelial cells, it acts as a chemotransmitter for inflammatory cells and it is a mitogen and chemotransmitter for fibroblasts and vascular smooth muscle cells [207]. Most cellular effects caused by thrombin are mediated by a family of G-protein receptors, called protease-activated receptors (PARs).

I.3.7 Prothrombotic factors and association with hepatic fibrosis

Leiden factor V and prothrombin G20210A mutations are considered the most common thrombophilia inherited among Caucasians. Leiden Factor V mutation (R506Q) confers resistance to activated protein C, which normally inactivates factor Va. The mutation causes a prothrombotic tendency. The pathophysiology between the G20210A prothrombin variant and thrombosis is still unclear, but in some subjects, this polymorphism is associated with elevated prothrombin levels that may promote thrombin generation.

I.3.9 Intrahepatic vessel microthrombi - possible causes of fibrosis and tissue ischemia

Another potential association between coagulation and fibrogenesis derives from human histopathology - studies in advanced CLD, which show thrombotic occlusion of small intrahepatic and sinus synodal veins in cirrhosis. In other words, thrombosis appears to be related to intimal fibrosis and subsequent vein obstruction. The resulting "parenchymal extinction" was defined as the irreversible loss of hepatocytes in a region and their replacement by fibrous tissue; this extinction was considered to be an event from the genesis and progression of fibrous septa and therefore from the onset of cirrhosis [27].

I.4. THROMBOTIC AND BLEEDING COMPLICATIONS IN PATIENTS WITH CHRONIC LIVER DISEASES

I.4.1 General notions

Hemorrhagic complications, especially in the gastrointestinal tract, can complicate the clinical course of cirrhosis of the liver. The liver synthesizes almost all coagulation factors, except factor VIII, which is synthesized by stellate and endothelial cells [210]. Coagulation factors are usually in small amounts, which coincides with liver damage, except for factor VIII, which is increased in quantity [191]. For many years, the reduced synthesis of coagulation factors has been considered responsible for abnormal laboratory tests that explore global coagulation activation, such as prothrombin time (PT) and partially activated thromboplastin (aPTT); they explained the risk of bleeding.

I.4.2. Spontaneous haemorrhages

I.4.2.1 Gastrointestinal bleeding

In patients with advanced liver disease, the most common bleeding is in the gastrointestinal tract. In most cases, it comes from specific places, such as Esophageal or gastric varices or ulcers.

1.4.2.2 Intracerebral haemorrhage

In a study that included 4,515 patients with liver cirrhosis hospitalized in Taiwan, the occurrence of spontaneous intracerebral haemorrhage was a rare complication (0.8%) and it was more closely related to the aetiology of the disease (0.3% for viral cirrhosis and 1.8% in ethanol), rather than to the severity of the liver disease. Indeed, no statistical differences were observed concerning them in the Child-Pugh score and prolonged PT [86].

1.4.3. Bleeding related to invasive procedures

1.4.3.1. Liver biopsy

Percutaneous liver biopsy is associated with a 0.08-0.7% risk of major intraperitoneal bleeding, with a general mortality rate secondary to a haemorrhage of 0.01-0.4%.

1.4.3.2. Paracentesis

Paracentesis is a safe procedure with a very low risk of bleeding [83]; common coagulation tests do not predict the risk of bleeding [118].

1.4.4. Thrombosis in chronic liver diseases

Not all hemostatic changes in patients with liver disease favour bleeding. The increase in thrombotic risk frequently explains thrombosis in the portal venous system, where patients with thrombophilia have the highest risk [140, 191,196,209]. In addition, conditions such as hepatic steatosis, nonalcoholic steatohepatitis and metabolic syndrome are favourable status for coagulation.

1.4.4.1 Portal vein thrombosis

The thrombotic mechanism appears to be mainly mediated by a decrease in the level of activated protein C; to this the reduction in the speed of portal blood flow and vascular wall abnormalities is added. The more severe the liver disease, the lower the levels of natural

anticoagulants. However, when the confounders are adjusted, the values of natural anticoagulants do not seem to predict portal vein thrombosis. The only predictor is a reduction in the rate of portal blood flow [76]. The development of portal vein thrombosis in these patients is independently associated with reduced C and S proteins and increased D-dimers [148].

1.4.4.2 Arterial thrombosis

Patients with chronic liver disease may develop atherothrombosis. It is unclear whether there is an increased risk of coronary heart disease or stroke in these cases. Arterial events such as hepatic artery obstruction after liver transplantation worsen the prognosis.

1.4.4.3 Peripheral venous thrombosis

Patients with advanced liver disease are not anticoagulants as once thought. Thrombotic events may occur even when laboratory tests suggest the risk of bleeding. The increase in the incidence of thrombosis can be explained by longer life and lifestyle changes caused by a sedentary lifestyle.

PART II

PERSONAL CONTRIBUTIONS

INTRODUCTION

The liver plays a central role in hemostasis, as it synthesizes most of the clotting factors and proteins involved in the fibrinolysis process [112].

Patients with cirrhosis of the liver have pathologically altered secondary haemostasis due to decreased plasma levels of pro- and anticoagulant factors synthesized in the liver, a clinical situation associated with an increased risk of haemorrhagic and thrombotic complications.

The study of thrombin generation in patients with cirrhosis of the liver reveals that this test more accurately assesses the risk of bleeding and thrombosis compared to conventional tests, as it takes into account both pro- and anticoagulant factors.

The study of the coagulation profile allows both the evaluation of the function of hepatocytes and the early detection of potential cellular lesions. Prolonged PT / INR and APTT, which are added to the progression of liver cirrhosis, indicate a functional and structural deterioration of the liver parenchyma which is associated with the decreased synthesis of proteins involved in coagulation, which carries a risk of bleeding. Conventional coagulation tests (prothrombin time - PT, activated partial thromboplastin time - APTT) do not accurately reflect complex changes in hemostasis in cirrhotic patients. In contrast, the thrombin generation test can provide more accurate information on the balance between procoagulant and anticoagulant factors, providing new insights into understanding the coagulation cascade.

The analyzed bibliographic sources show that the study of thrombin generation aims at the global evaluation of hemostasis, providing information about the early stages, amplification or propagation and resolution.

GENERAL OBJECTIVES OF THE RESEARCH

The main objective of this thesis was to analyze the status of coagulation in patients with chronic liver disease, by investigating the parameters of thrombin generation from poor plasma into platelets and comparing the values obtained with those of a control group of healthy subjects.

The secondary objective was to analyze the possible correlation between the degree of hepatic fibrosis and the level of thrombin generation in patients with chronic liver disease,

and the study a possible correlation between tests that explore non-invasive hepatic fibrosis and predict the risk of Esophageal variceal bleeding.

GENERAL RESEARCH METHODOLOGY

To achieve the above objectives, a prospective observational clinical study was performed, which included all patients with chronic liver disease hospitalized in the departments of Gastroenterology and Internal Medicine of the Sibiu County Emergency Clinical Hospital, between January 2016 and March 2018.

The research protocol complies with national and international norms regarding medical research and was approved by the Ethics Council of the Sibiu County Emergency Clinical Hospital.

We included in the control group subjects without a history of thrombotic or hemorrhagic events, symptoms of acute infection or chronic inflammatory disease, without antiplatelet, anti-inflammatory or anticoagulant treatment.

In both study groups, the preanalytical conditions, as well as the thrombin generation measurement technique, were identically observed.

For each subject included in the study, the following demographic and clinical data were noted: age, gender, height, weight, body mass index (BMI), pathological history (thrombotic and/or diagnosis of thrombophilia, other current conditions), aetiology of chronic liver disease, Child-Pugh score and grade [95].

Thrombin generation was analyzed from platelet-poor plasma using the Technothrombin® TGA Reagent Kit (Technoclone, Vienna, Austria) for fully automated Ceveron® alpha [142]. The acquisition of the necessary materials was financially supported by "Lucian Blaga" University of Sibiu through the research grant **LBUS-IRG-02.2016**.

The device determined the following parameters: Lag time (phase) (min), Peak time (min), Peak thrombin (nM), velocity index or slope (nM/min) and area under the curve or endogenous thrombin potential (nM/min) [142].

Other blood samples were collected from each patient for haematological tests: plasma fibrinogen, International Normalized Ratio (INR), Prothrombin Time (PT), Partially Activated Thromboplastin Time (APTT).

The degree of liver fibrosis was assessed by transient elastography (FibroScan), a non-invasive method for determining liver tissue elasticity. The result is expressed in kilopascals and it is the median value of at least 10 measurements.

STATISTICAL ANALYSIS

- To statistically analyze the resulting data, a database was created in which each subject included in the study was assigned a unique identification code. The database thus created was analyzed using SPSS software version 21.0 (SPSS Inc., Chicago, IL, USA) and various software packages.
- A value of $p < 0.05$ was considered to have statistical significance.

ETHICAL CONSIDERATIONS

The personal research clinical trial was conducted based on a research protocol developed by national and international requirements in the field of medical research on human subjects and accordance with the principles set out in the Declaration of Helsinki. The protocol was approved by the Ethical Council of the Sibiu County Emergency Clinical Hospital, No. **22524 / 03.10.2016**. Subjects selected according to the inclusion and exclusion criteria presented above were included in the study only after signing the informed consent (Annex).

1. THROMBINE GENERATION IN CHRONIC LIVER DISEASES - PILOT STUDY

II.1.1 Introduction

Excessive alcohol consumption, obesity (including in children and young people) and liver virus infections are the main etiological factors of chronic liver disease, which is represent a public health problem worldwide [152]. The availability of new and effective treatment options for chronic viral hepatitis [4] and the increasing prevalence of obesity are, over time, leading to a change in the proportion of major etiologies of chronic liver disease. Non-alcoholic hepatic steatosis, which is the hepatic manifestation of metabolic syndrome, is already the leading cause of chronic liver disease worldwide [104] and cirrhosis is considered to be cryptogenic [4]. The study of thrombin generation can best estimate whether patients with chronic liver disease have a higher risk of thrombosis or bleeding [30] and allows a personalized therapeutic approach.

In this study, we decided to analyze thrombin generation in a group of hospitalized patients with chronic liver disease to estimate their thrombotic or hemorrhagic risk, depending on the stage and aetiology of the disease. In addition, we analyzed the factors that may influence the level of thrombin generation and the individual risk of thrombosis or bleeding in these patients.

The objective of the study

1. The general objective of this study was to analyze the status of coagulation in patients with chronic liver disease, by investigating the parameters of thrombin generation from poor plasma into platelets.
2. Determination of plasma thrombin levels in patients with the chronic liver disease compared to a control group..

II.1.2. Material and method

We conducted a prospective observational study between January 2017 and March 2018, which included all patients with chronic liver disease hospitalized in the departments of Gastroenterology and Internal Medicine of the Sibiu County Emergency Clinical Hospital. The study was approved by the hospital's Ethics Committee and ensured the confidentiality of patients' data.

The following data were analyzed: age, height, weight, body mass index (BMI), possible thrombotic history or diagnosis of thrombophilia, other current conditions, aetiology of chronic liver disease, Child-Pugh score and class [95].

The device determined the following parameters: Lag time (phase) (min) (measured from the time the TGA reagents were added to the first thrombin-generating explosion), Peak time (min) (the time required to reach the maximum thrombin concentration produced), Peak thrombin (nM), velocity index or slope (nM/min) and area under the curve or endogenous thrombin potential (nM/min) (total thrombin concentration generated over time) [141].

Other blood samples were collected from each patient for plasma fibrinogen, International Normalized Ratio (INR), Prothrombin Time (PT), and Partially Activated Thromboplastin Time (APTT). The complete blood count was performed with the Sysmex XT2000i analyzer and coagulation tests with the CA1500 coagulometer.

The data obtained were recorded in Microsoft Excel files, and then statistically processed to compare the parameters of thrombin generation of patients with chronic liver disease (depending on diagnosis, Child-Pugh class and aetiology) with those of patients in the control group.

Statistical analysis

Continuous data are presented using the median and interquartile range. Their normality was assessed using the Shapiro-Wilk test. Comparisons between groups of independent variables (two or more) were performed with the Mann - Whitney U nonparametric test and the Wilcoxon tests. In the case of categorical data, Chi-square and Fischer's exact test was used to analyze statistical differences between groups. A p value of 0.05 was considered statistically significant. Statistical analyzes and graphs were performed with SPSS 21.0 software version (SPSS Inc., Chicago, IL, USA) and using different packages from the R software.

II.1.3. Result

Lag time and t Peak are higher in patients with cirrhosis of the liver, with a statistically significant difference between those in the Child-Pugh B class compared to the control group ($p < 0.05$). A significant difference was also found in the comparison of ETP (endogenous thrombin potential) values of patients with liver cirrhosis with control subjects - 1993.80 nM / min (649.9; 2920.4) compared to 2,620.30 nM / min (467 , 7; 2991.0). The same situation was encountered in the case of Peak and VI ($p = 0.000$) (see Table 3).

Table no.3.3.3. Median values of thrombin generation parameters (controls and patients)

	Chronic hepatitis (n=19)	Liver cirrhosis (n=40)	Child Pugh A (n=16)	Child Pugh B (n=19)	Child Pugh C (n=5)	Patients (n=59)	Controls (n=62)
Lag time (min)	3.40 (2.4;5.0) 0.140	3.80 (2.5;9.3) 0.082	3.65 (2.5;9.3) 0.714	4.10 (3.1;5.2) 0.008	3.60 (3.3;4.0) 0.772	3.70 (2.4;9.3) 0.528	3.65 (2.6;11.4)
tPeak (min)	6.80 (4.9;9.0) 0.138	7.65 (5.3;14.6) 0.080	7.15 (5.3;14.6) 0.946	8.40 (6.5;9.9) 0.007	7.20 (6.6;8.5) 0.862	7.25 (4.9;14.6) 0.527	7.15 (5.5;20.7)
Peak (nM)	228.20 (121.8;440.4) 0.012	175.00 (38.3; 371.5) 0.000	217.15 (132.9; 371.5) 0.001	169.70 (38.7; 274.1) 0.000	102.80 (38.3; 116.1) 0.000	193.55 (38.3; 440.4) 0.000	313.30 (31.9;475.0)
VI (nM/min)	62.00 (26.7;175.7) 0.157	45.90 (8.5;123.7) 0.000	61.00 (27.7;123.7) 0.056	39.90 (8.7;81.6) 0.000	29.20 (8.5;35.1) 0.000	52.40 (8.5;175.7) 0.000	88.40 (4.8;164.3)
ETP (nM/min)	2.191.30 (1430.1; 2836.5) 0.000	1.923.40 (649.9; 2920.4) 0.000	2.147.90 (1657.8; 2920.4) 0.000	1.870.30 (704.5; 2484.5) 0.000	1.181.00 (649.9; 1525.2) 0.000	1.993.80 (649.9; 2920.4) 0.000	2.620.30 (467.7; 2991.0)

Legendă : Valorile parametrilor sunt reprezentate sub formă de mediană, interval interquartilic și nivel de semnificație statistică (p), tPeak=peak time, Peak=peak thrombin, VI=velocity index; ETP= endogenous thrombin potential

Depending on the aetiology of chronic liver disease, it can be seen that patients with ethanolic aetiology have a significantly higher Lag time compared to the control group (4 min (2.7; 9.3) vs. 3.65 min (2.6; 11.4), $p < 0.05$). Thrombin Peak and ETP were significantly lower in all aetiologies compared to the control group ($p < 0.05$). VI was significantly lower in C, ethanolic and mixed aetiology hepatopathies compared to control subjects ($p < 0.05$).

II.1.4. Discussions

The present study reveals that most of the values of the parameters investigating thrombin generation were significantly lower in patients with chronic hepatitis compared to controls; similar results were found in patients with cirrhosis compared to the control group.

In addition, significantly lower values were found in cirrhotic patients compared to patients with chronic hepatitis. In other words, thrombin generation decreases as hepatopathy progresses.

The results of our study showed that the Lag phase and t Peak are high, and ETP, Peak and VI had much lower values in liver cirrhosis compared to the control group. The interpretation of the five parameters of thrombin generation in our study identifies a hypocoagulable status in patients with chronic liver disease. Arguments for hypocoagulable status in cirrhotic patients include: the presence of hypofibrinogenemia (but the molecule has procoagulant properties), decreased clot formation, and stability observed in some studies using viscoelastic testing, discontinuation of fibrin polymerization (delayed), and greater fibrin [16].

In our study, the value of ETP was significantly lower in patients with cirrhosis of the liver compared to the control group. A decreasing trend of ETP was observed with the increase of the Child-Pugh Score, but it is significant only when the Child-Pugh Classes are compared to each other (A to C). Decreased thrombin generation parameters as liver disease severity increases may indicate a slight decrease in procoagulant potential, which may be offset by an increase in thrombin generation rate.

Low ETP and high Peak were the results of another study by Zermatten et al. [213] In a prospective monocentric study, including 260 patients with liver cirrhosis, an attempt was made to measure thrombin generation using the ST Genesia Thrombin Generation System with and without the addition of thrombomodulin (TM). Without TM, the values of the ETP and Peak parameters were similar to those of the control group. These parameters have a decreasing tendency with increasing severity of cirrhosis, depending on the Child-Pugh score. In this study, they demonstrated that patients with cirrhosis of the liver have an increasing prothrombotic profile, correlating with altered biomarkers of liver dysfunction [214].

This study has several limitations. Firstly, the number of study subjects was relatively small, especially those with Child-Pugh C-class liver cirrhosis, due to the fact that this is a pilot and monocentric study, and the results should be analyzed in larger groups of patients. Secondly, the age of patients with chronic liver disease was higher than that of healthy controls. However, it has been shown in dedicated studies that within the general population, age does

not have a large impact on thrombin generation. In addition, in patients with cirrhosis of the liver, this effect is even smaller because the changes produced by liver cirrhosis on the coagulation cascade, disrupt the effect that age has on the plasma levels of coagulation factors [100]. Thirdly, our study was performed without the addition of thrombomodulin, according to Lisman's study [75], this is not an appropriate way to assess the coagulation status of patients with cirrhosis of the liver. Fourthly, there were insufficient data to establish the smoking status in both the study group and the control group, knowing that smoking can influence platelet aggregation.

II.1.5. Conclusions

1. In the current study, the time required to start thrombin generation and to reach the maximum thrombin concentration produced (reflected in the Lag time and t Peak parameters) had significantly higher values in patients with hepatic cirrhosis class Child Pugh B compared to the control group. ($p < 0.05$).
2. Plasma samples collected from patients with chronic liver diseases of ethanolic aetiology showed a significantly higher Lag time compared to those in the control group ($p < 0.05$).
3. The values of Peak, VI and ETP parameters in plasma samples from patients with chronic liver disease of all etiologies were significantly lower than in the control group ($p < 0.05$).
4. In our study, the plasma of patients with chronic liver disease generates less thrombin compared to the control group. In cirrhotic patients, thrombin generation decreases along with the increase of the severity of liver cirrhosis (significantly lower in Child-Pugh C than A). However, given the variability in thrombin generation in patients with chronic liver disease, its dosage could be used to identify those at high risk of bleeding or thrombosis and to establish their personalized treatment.

II.2. STUDY OF THE CORRELATION BETWEEN THROMBIN GENERATION AND HEMOLEUCOGRAM PARAMETERS, CLASSICAL EXPORING COAGULATION TESTS AND BIOCHEMICAL TESTS

II.2.1. The current state of knowledge

Patients with chronic liver disease may experience substantial changes in the hemostatic system, as the liver is responsible for the synthesis of all factors involved in homeostasis. Conventional coagulation test values, such as prothrombin time (PT) and activated partial thromboplastin time (APTT), are prolonged in patients with cirrhosis of the liver, suggesting a tendency to bleed. However, PT and APTT are only sensitive to changes in procoagulant factors, reflecting only the abnormalities of pro-coagulating proteins in liver cirrhosis, and provide little information on anticoagulant factors, including antithrombin and protein pathway C proteins. This has led to the concept of rebalanced hemostasis used to explain the complexity of coagulation profiles in patients with chronic liver disease [115, 112, 184]. Although a hemostatic balance is reached in liver cirrhosis, it is more fragile and can easily tilt to a hypo- or hypercoagulant status; however, conventional coagulation tests are not suitable for assessing the coagulation profile in these patients [208].

Objectives of the study

- The main objective of this study is to investigate the relationship between biomarkers of liver dysfunction and thrombin generation
- The secondary endpoint is the assessment of thrombotic or haemorrhagic risk in patients with chronic liver disease.

II. 2.2. Material and method

We conducted a prospective observational study between January 2017 and March 2018, which included all patients with chronic liver disease in the gastroenterology and internal medicine departments of the Sibiu County Emergency Clinical Hospital. The study was approved by the hospital's Ethics Committee and ensured the confidentiality of patients' data. A blood sample was collected from each control subject and patient in 4.5 ml CTAD glass tubes (citrate-theophylline-adenosine-dipyridamole Vacutainers®, Beckton Dickinson), containing 3.2% 0.109M sodium citrate. Thrombin generation was performed from platelet-

poor plasma using the Technothrombin® TGA reagent kit (Technoclon, Vienna, Austria) for Ceveron® alpha - a fully automated apparatus [142].

The device determined the following parameters: lag phase (phase) (min), peak time (min), peak thrombin (nM), velocity index or slope (nM/min) and area under the curve or endogenous thrombin potential (nM) [142].

Other blood samples were collected from each patient to determine platelet counts (average platelet volume, platelet distribution width, platelet count), erythrocyte sedimentation rate (ESR), plasma fibrinogen (Fibr.), International Standard Report (INR), prothrombin time (PT), partially activated thromboplastin time (APTT), blood glucose, total bilirubin, serum alkaline phosphatase (SAP), gamma-glutamyl transpeptidase (GGT), alanine aminotransferase (ALT), total aspartate aminotransferase serum (AST), total proteins (Prot T), albumin and gamma-globulins, total plasma cholesterol (Col), HDL-plasma cholesterol, plasma triglycerides (TGL), serum creatinine and urea.

Statistical analysis

Statistical analysis was performed with SPSS version 20 and graphics were generated using R software. Data normality was assessed using the Shapiro-Wilk test. Continuous data are presented as mean and standard deviation, minimum, maximum, median and interquartile range (IQR). Comparisons between two independent groups were performed using the Mann-Whitney test, while for three independent groups the Kruskal-Wallis test was used. A p value <0.05 was considered statistically significant.

II.2.3. Result

The results obtained in the study of the correlation between the parameters of the hemoleukogram and those of thrombin generation: Ht correlates directly with Peak ($\rho = 0.377$, $p = 0.003$) and with VI ($\rho = 0.293$, $p = 0.024$). A direct correlation also exists between thrombocytocrit and parameters: Peak ($\rho = 0.521$, $p = 0.000$), VI ($\rho = 0.509$, $p = 0.000$) and ETP ($\rho = 0.463$, $p = 0.000$) (Table no.2.3.5) .

In our study the number of platelets correlates directly with the parameters: Peak ($\rho = 0.509$, $p = 0.000$), VI ($\rho = 0.504$, $p = 0.000$) and with ETP ($\rho = 0.460$, $p = 0.000$, Figure no.2.3. 1).

Figure no. 2.3.1. Correlation between platelets and thrombin generation parameters

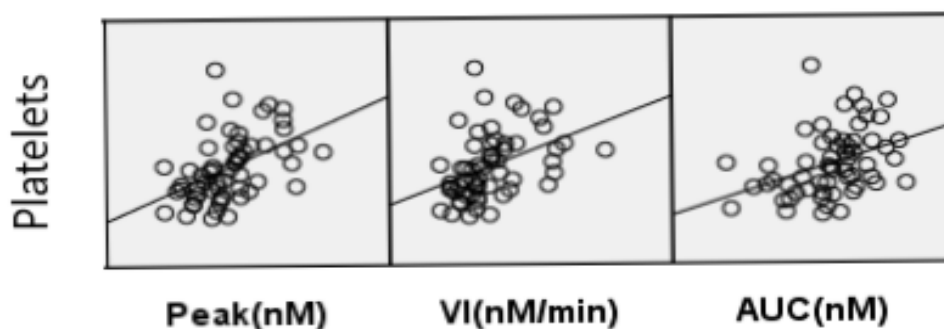

The results obtained in the study of the correlation between the conventional tests of coagulation and those of thrombin generation are presented in Table no. 2.3.6.

Our study highlighted the following correlations between biochemical analyzes and thrombin generation parameters: AST correlates inversely with parameter VI ($\rho = -0.276$, $p = 0.034$). Bt correlates directly with the parameters Lag phase ($\rho = 0.300$, $p = 0.021$) and tPeak ($\rho = 0.400$, $p = 0.002$) and correlates inversely with the parameters: Peak ($\rho = -0.571$, $p = 0.000$), VI ($\rho = -0.607$, $p = 0.000$), and ETP ($\rho = -0.643$, $p = 0.000$). Bd correlates inversely with the parameters: Peak ($\rho = -0.722$, $p = 0.000$), VI ($\rho = -0.722$, $p = 0.000$), and ETP ($\rho = -0.760$, $p = 0.000$). FAS correlates directly with the parameters: Lag phase ($\rho = 0.348$, $p = 0.007$) and tPeak ($\rho = 0.414$, $p = 0.001$) and vice versa with the parameter VI ($\rho = -0.325$, $p = 0.012$, Figure No. 2.3.3).

Figure no.2.3.3. The correlation between biochemical tests and thrombin generation parameters

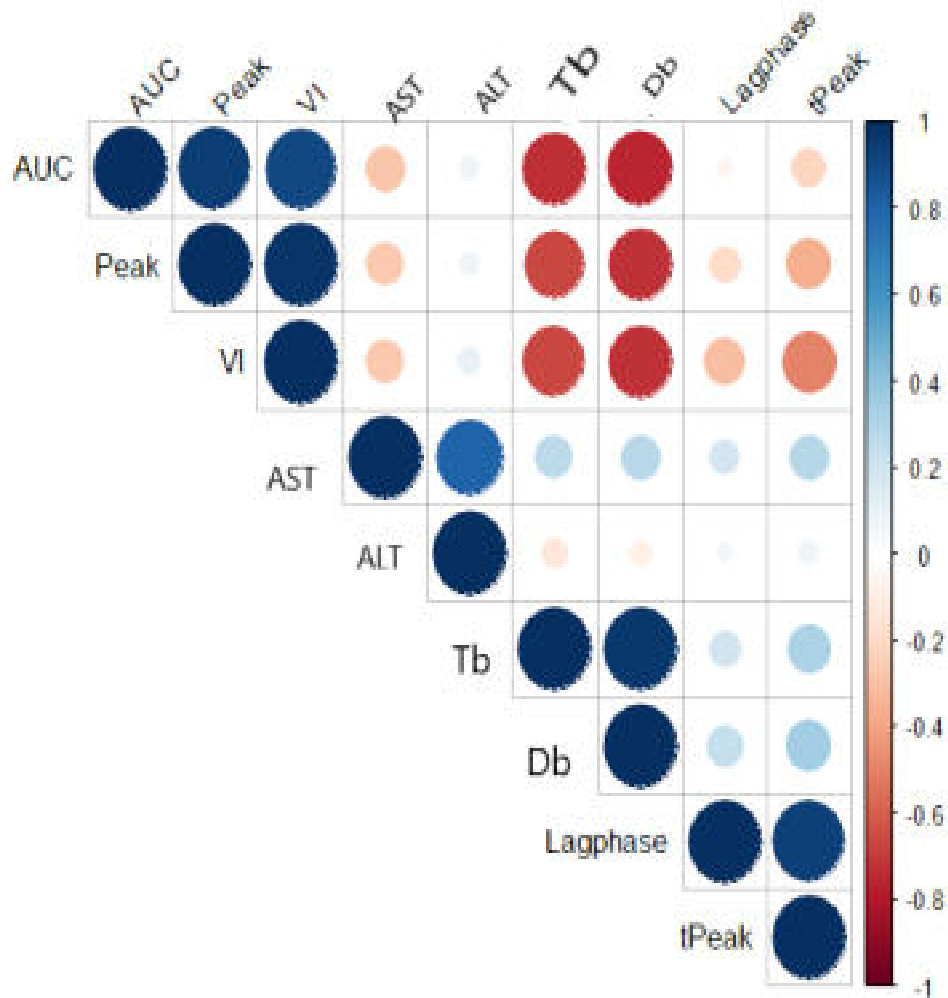

II.2.4. Discussions

In the current study we observed a direct correlation between Ht and Peak parameters ($\rho = 0.377$, $p = 0.003$) and VI ($\rho = 0.293$, $p = 0.024$). PLT correlates directly with the parameters: Peak ($\rho = 0.509$, $p = 0.000$), VI ($\rho = 0.504$, $p = 0.000$) and ETP ($\rho = 0.460$, $p = 0.000$). There is also a direct correlation between thrombocytocrit and parameters: Peak ($\rho = 0.521$, $p = 0.000$), VI ($\rho = 0.509$, $p = 0.000$) and ETP ($\rho = 0.463$, $p = 0.000$). The results we obtained are consistent with those discovered by Tripodi et al. [185]; they point out that platelet counts in patients with cirrhosis of the liver may play a key role in thrombin

generation and possibly in the tendency to bleed. Thrombin generation may be normal in the plasma of people with cirrhosis of the liver and this may warrant platelet transfusion or recombinant human thrombopoietin treatment in those patients with severe thrombocytopenia, when they bleed spontaneously, before undergoing surgery or a liver biopsy. Platelets have phospholipid surfaces that complete the generation of thrombin in plasma. The study by Tripodi concluded that severe thrombocytopenia may limit thrombin generation in patients with cirrhosis of the liver [185].

Thus, in addition to a reduction in the number of circulating platelets, it was found that there was a functional defect in platelets. Impaired platelet function may be the result of a storage defect, transmembrane signal transduction, low arachidonic acid required for thromboxane A₂ membrane production, and decreased platelet receptor function as a consequence of plasma proteolysis. In addition, the abnormal presence of high-density lipoproteins and low hematocrit [19, 108] may affect platelet function in vivo. Finally, the increased production of two important inhibitors of platelets derived from endothelium (nitric oxide and prostacyclin) may contribute to the poor activation of platelets in vivo [114].

We observed in our study that APTT correlates directly with the parameters Lag phase and tPeak and correlates inversely with the parameters Peak, VI and ETP; PT correlates directly with Lag phase and tPeak parameters and correlates inversely with Peak, VI and ETP parameters.

We observed a direct correlation between plasma fibrinogen and the parameters: Peak, VI and ETP. According to data obtained by Siddiqui et al., They found a significant correlation between decreased plasma fibrinogen levels and gastrointestinal bleeding in patients with cirrhosis of the liver. Hypofibrinogenemia, which is commonly seen in patients with advanced liver cirrhosis, increases the risk of bleeding, as fibrinogen serves both as a precursor to fibrin and as a mediator of platelet aggregation [14]. The risk of bleeding is especially important when the fibrinogen level is below 1 g / L [28].

Another direct correlation that we observed was between Bt and the parameters Lag phase and tPeak and its inverse correlation with the parameters: Peak, VI, and ETP. According to studies, the relationship between total bilirubin and prothrombotic profile can be seen, which is probably related to the severity of liver dysfunction. However, some published data support a direct association between bilirubin and hypercoagulant status [20, 78].

An inverse correlation was also noted between the parameters of Lag phase thrombin generation ($\rho = -0.382$, $p = 0.003$,) and tPeak ($\rho = -0.395$, $p = 0.002$) and albumin.

Albuminemia was also directly correlated with Peak ($\rho = 0.339$, $p = 0.010$) and VI ($\rho = 0.323$, $p = 0.014$). As in our study, Zermatten G.M et al. [214] described an inverse correlation between serum albumin and prothrombotic hemostatic profile in patients with liver cirrhosis. Various studies have shown that high INR, low serum albumin and high bilirubin are risk factors involved in the development of portal vein thrombosis [9,18].

In our study we observed that HDL-col correlates directly with the parameters: Peak ($\rho = 0.455$, $p = 0.033$), VI ($\rho = 0.480$, $p = 0.024$) and ETP ($\rho = 0.522$, $p = 0.013$). In a retrospective study that included 117 patients with cirrhosis of the liver and non-malignant portal vein thrombosis, Gao B. et al. [66] have tried to demonstrate a possible correlation between the lipid profile (triglycerides, cholesterol, HDL-C and LDL-C) and liver function, and whether these correlations may be useful in predicting mortality 1 year after the diagnosis of liver cirrhosis with thrombosis of the non-malignant portal vein.

II.2.5. Conclusions

1. We observed a direct correlation, with statistical significance, between platelets and thrombin generation parameters (Peak, VI, ETP); this is explained by the involvement of platelets in the pathogenesis of hemostasis in chronic liver diseases, by their quantitative and qualitative changes.
2. Diagnostic, prognostic and evolutionary biomarkers used in chronic liver diseases (platelets, hematocrit, INR, APTT, Bt, Bd, Albuminemia and gammaglobulinemia) are significantly correlated with thrombin generation parameters. As a result, they can also be used to identify the risk of these patients developing the bleeding complications induced by the investigated liver pathology; they can be used to calculate bleeding risk scores in patients with chronic liver disease.

II.3. STUDY OF THE CORRELATION BETWEEN THROMBIN GENERATION AND LIVER FIBROSIS

II.3.1. Current state of knowledge

In the liver tissue repair mechanism, stellate liver cells (CHS) are recruited at the site of injury, and the changes they undergo reflect paracrine stimulation by all cell types (sinusoidal endothelial cells, Kupffer cells, hepatocytes, platelets), and platelets.

Thrombin converts fibrinogen to fibrin, platelet aggregation, it is an intense stimulator of endothelial cells, it acts as a chemotactic factor for inflammatory and fibroblast cells, and it is mitogenic for vascular smooth muscle cells. The cellular effects of thrombin are mediated by coupled G protein-coupled receptors called protease-activated receptors (PARs). All known members of the PAR family stimulate the proliferation/activation of stellate liver cells [23].

Liver fibrogenesis is a dynamic process involving complex cellular and molecular mechanisms, leading to chronic activation of liver tissue repair mechanisms. One of the first steps in tissue repair is to recruit inflammatory cells in order to neutralize possible infections and remove necrotic tissue. At this stage of the process, stellate liver cells (CHS), as well as other cells in the extracellular matrix (eg, fibroblasts and myofibroblasts), are recruited at the site of injury and undergo an activation process, leading to a phenotype characterized by increased proliferative properties, motility and contractility [153]. Changes in stellate liver cells reflect paracrine stimulation by all neighbouring cell types, including sinusoidal endothelium, Kupffer cells, hepatocytes, platelets, and leukocytes [63].

Objectives of the study

- Analysis of a possible correlation between the degree of liver fibrosis and thrombin generation in patients with chronic liver disease.
- Study of a possible correlation between tests that explore non-invasive liver fibrosis and the prediction of the risk of bleeding oesophageal varices.

II.32. Material and method

We conducted a prospective observational pilot study between January 2017 and March 2018, which included all patients with chronic international liver disease in the gastroenterology and internal medicine sections of the Sibiu County Emergency Clinical Hospital.

All subjects agreed to participate and signed the informed consent (World Medical Association Code of Ethics, Helsinki Declaration). The study was approved by the hospital's Ethics Committee which ensures the patient's personal data confidentiality.

- Delay time (phase) (min), Peak thrombin (nM), Peak time (min), Speed index and Area under the curve (AUC) (nM). The Ceveron® alpha automatic analyzer has four measurement channels with TGT fluorometric module consisting of UV LED (365nm) for excitation and a photodiode for measuring the emitted signal, placed in the cuvette rotor (thermostat), according to the study by Olteanu et al. [141,142].

The degree of liver fibrosis was assessed by transient elastography (FibroScan), after non-invasive to determine the elasticity of liver tissue. This is a quick, painless, sedation-free solution. This technique uses a special probe to generate vibration waves of 50 Hz frequency and 2 mm amplitude. The result is expressed in kilopascals and is the median value of at least 10 measurements.

All patients with liver cirrhosis were examined by upper gastrointestinal endoscopy to assess the degree of oesophageal varices using the EVIS EXERA 3 Flexible Video Gastroscope (Olympus Japan). Esophageal varices were classified according to their size.

Statistical analysis

The statistical analysis of the recorded clinical and paraclinical data, and the presented graphics were performed using the SPSS program, version 20 and the R software. The distribution of numerical data was evaluated using Shapiro-Wilk. Numerical data are presented as mean \pm standard deviation, minimum and maximum value, median and interquartile range (IQR). Comparisons between two groups of data were performed for independent tests, while three independent groups were used for the Kruskal-Wallis test. A p value <0.05 was considered statistically significant.

II.3.3. Results

In this study, we can observe the parameters of thrombin generation depending on the stages of liver fibrosis (Table no. 3.3.1) as well as the fact that the Peak parameter is significantly

higher in those with F3 (median 295.5, IQR: 203.30-341.20) compared to those who have a more advanced degree of fibrosis - F4 (median 175, IQR: 132.90-228.10; $p < 0.05$); also AUC and VI (the latter is close to statistical significance) are higher in those with F3, compared to those with F4 ($p < 0.05$) (Figure no.3.3.1).

Table no.3.3.1. Thrombin generation parameters depend on the liver fibrosis stages

	F2	F3	F4	p
Lag phase (min)	3,05±0,49 (2,70;3,40) 3,05 (2,70;3,40)	3,42±0,94 (2,40;5,00) 3,70 (2,50;4,10)	4,02±1,03 (2,60;9,30) 3,80 (3,40;4,30)	0.098
tPeak(min)	6,00±1,13 (5,20;6,80) 6,00 (5,20;6,80)	7,02±1,49 (4,90;9,00) 6,90 (5,50;8,20)	7,83±1,52 (5,30;14,60) 7,55 (7,00;8,50)	0.105
Peak(nM)	256,15±69,65 (206,90;305,40) 256,15 (206,90;305,40)	278,11±103,32 (121,80;440,40) 295,50 (203,30;341,20)	179,44±71,53 (38,30;371,50) 175,00 (132,90;228,10)	0.022
VI(nM/min)	72,65±16,90 (60,70;84,60) 72,65 (60,70;84,60)	87,33±49,64 (26,70;175,70) 85,60 (47,50;122,20)	51,31±26,54 (8,50;123,70) 45,95 (33,40;65,00)	0.053
AUC(nM)	2279,05±586,69 (1864,20;2693,90) 2279,05 (1864,20;2693,90)	2334,49±409,33 (1650,20;2836,50) 2427,90 (2191,30;2669,70)	1878,95±487,72 (649,90;2920,40) 1974,30 (1613,40;2236,00)	0.044

Caption: * Quantitative variables are expressed as mean ± standard deviation, median (interquartile range); tPeak = peak time, Peak = peak thrombin, VI = velocity index; AUC = area under the curve, F2 = Stage 2 fibrosis, F3 = Stage 3 fibrosis, F4 = Stage 4 fibrosis

Regarding the classification according to diagnosis: chronic hepatitis (F2 + F3) and liver cirrhosis (F4), we can observe that Lag phase is significantly higher in those with F4 (median 3.80, IQR: 3.40 - 4.30), compared to those in the F2 + F3 group (median 3.40, IQR: 2.50 - 4.10, $p < 0.05$), while VI is significantly lower in those with F4 (median 45.95, IQR: 33.40 - 65.00) than those with F2 + F3 (median 84.60, IQR: 47.50 - 122.20, $p < 0.05$). AUC is also lower in those with F4 fibrosis (median 1974.40, IQR: 1613.40 - 2236.00) than in those with F2 + F3 (median 2427.20, IQR: 1864.20 - 2693.90; $p < 0.05$).

Thus, the Forns index is inversely correlated with the parameters: Peak ($\rho = -0,508$, $p = 0.000$); VI ($\rho = -0.501$, $p = 0.000$); AUC ($\rho = -0.466$, $p = 0.000$);).

We also studied the possible correlation between another non-invasive marker of liver fibrosis and thrombin generation parameters: the AST / ALT ratio. The AST / ALT ratio correlates directly with Lag phase ($\rho = 0.383$, $p = 0.003$), tPeak ($\rho = 0.360$, $p = 0.005$) and vice versa with Peak ($\rho = -0.283$, $p = 0.032$).

The non-invasive diagnosis of liver fibrosis remains a challenge in today's medicine, so the APRI score was developed to diagnose severe fibrosis and liver cirrhosis in chronic liver diseases. The correlation between the APRI score and the thrombin generation parameters is highlighted. The APRI score correlates inversely with the parameter Peak ($\rho = -0.423$, $p = 0.001$), VI ($\rho = -0.482$, $p = 0.000$) and AUC ($\rho = -0.501$, $p = 0.000$).

Another non-invasive index for which we tried to highlight a possible correlation with thrombin generation parameters is the spleen's platelet score / long axis.

Platelet score / long spleen axis correlates inversely with tPeak ($\rho = -0.418$, $p = 0.000$) and directly with the parameter Peak ($\rho = 0.564$, $p = 0.000$), VI ($\rho = 0.532$, $p = 0.000$) and AUC ($\rho = 0.505$, $p = 0.000$).

An evolution towards chronicity - chronic hepatitis, liver cirrhosis and finally the appearance of hepatocellular carcinoma - can occur over the years. The existence of a possible correlation between the rate of progression of liver fibrosis and the parameters of thrombin generation tried to analyze in our study.

The rate of progression of liver fibrosis is inversely correlated with the parameters: Lag phase ($\rho = -0.324$, $p = 0.030$) and tPeak ($\rho = -0.384$, $p = 0.009$) and directly with the parameters: Peak ($\rho = 0.460$, $p = 0.001$) and VI ($\rho = 0.417$, $p = 0.004$).

The Forns index correlates directly with the degree of VE ($\rho = 0.303$, $p = 0.021$) and with the long axis of the spleen ($\rho = 0.584$, $p = 0.000$). The AST / ALT ratio correlates directly with the degree of esophageal varices ($\rho = 0.381$, $p = 0.003$), with the long axis of the spleen ($\rho = 0.381$, $p = 0.003$) and with the diameter of the portal vein ($\rho = 0.361$, $p = 0.006$). Platelet / spleen long axis score correlates inversely with VE degree ($\rho = -0.255$, $p = 0.053$), spleen long axis ($\rho = -0.515$, $p = 0.000$) and portal vein diameter ($\rho = -0.366$, $p = 0.011$).

The long axis of the spleen correlates directly with the parameters Lag phase ($r = 0.323$, $p = 0.013$) and tPeak ($r = 0.371$, $p = 0.004$) and correlates inversely with the parameters Peak ($r = -0.359$, $p = 0.006$) and VI ($r = -0.331$, $p = 0.011$). The same direct correlations were between VP diameter and Lag phase parameters ($r = 0.369$, $p = 0.004$) and tPeak ($r = 0.387$, $p = 0.003$); respectively inverse correlations with the parameters Peak ($r = -0.403$, $p = 0.002$) and VI ($r = -0.363$, $p = 0.005$), (Figure no 3.3.10). There were no correlations between thrombin generation parameters and the degree of esophageal varices.

II.3.4. Discussions

In this study, we found that there are significant differences in thrombin generation depending on the degree of liver fibrosis. Patients with a higher degree of liver fibrosis had a significantly higher Lag phase parameter, while Peak, VI and AUC parameters were significantly lower in patients with F4 fibrosis compared to those in the F3 group; this assumes that thrombin generation decreases not only as chronic liver disease and liver fibrosis progress but also as Child-Pugh (in patients with cirrhosis of the liver) increases.

The results of our study are similar to those of Dillon MB et al [48] who conducted a study that included 61 patients with compensated liver cirrhosis. They studied the characterization of thrombin generation in patients with Child A class cirrhosis of the liver and observed that the coagulation parameters change on the evolution of liver cirrhosis.

In our study, ETP was significantly lower in patients with F4 fibrosis compared to those with F3; the same results were obtained by Brodard J. et al. [17] in a study of 78 patients with chronic liver disease (ACLD), where they looked at whether the parameters of thrombin generation correlated with liver stiffness].

The Forns index was inversely correlated with Peak, VI, ETP, and the APRI score was indirectly correlated with Peak, VI, and ETP parameters. The main reason for the decrease in thrombin generation with the progression of chronic liver disease is the deficiency of coagulation factors, supported by prolonged INR, PT and aPTT values. We note that only 5 patients with cirrhosis of the liver were in the Child-Pugh C class, which could influence our study.

The rate of progression of liver fibrosis was inversely correlated with the parameters: Lag phase and tPeak and directly with the parameters: Peak and VI. In other words, the more active the fibrogenesis, the higher the latency phase in thrombin generation and the higher the value of the Peak t parameters.

II.3.5. Conclusions

1. In our study we found that thrombin generation decreases with the progression of liver fibrosis (thrombin generation parameters were significantly lower in patients with F4 fibrosis compared to those with F3).
2. Thrombin generation decreases as estimated liver fibrosis by noninvasive tests (excluding platelet count / long spleen axis) increases. Thus, the Forns index is inversely correlated with the parameters: Peak, VI, and AUC; the AST / ALT ratio correlates directly with Lag phase and tPeak and vice versa with Peak; the APRI score

correlates inversely with the Peak, VI and AUC parameter and the platelet/spleen long axis score correlates inversely with tPeak and directly with the Peak, VI and AUC parameters.

3. Indices of non-invasive assessment of liver fibrosis can be calculated at no additional cost and can contribute to improving the medical management of children with chronic liver disease, by limiting liver puncture-biopsy and endoscopic examinations in at-risk studies, or hospitals where upper digestive endoscopy is not medically available.

II.4. RISK FACTORS REGARDING THROMBOTIC AND BLEEDING COMPLICATIONS IN CHRONIC LIVER DISEASES

II.4.1. Current state of knowledge

Patients with chronic liver disease are at increased risk for both thrombotic and hemorrhagic complications. In chronic hepatopathies, multiple pathophysiological changes occur because at the hepatic level the coagulating factors, the anticoagulants, and the proteins involved in fibrinolysis and thrombopoietin with a role in platelet production are synthesized [107,109,186]. Hepatic dysfunction leads to an imbalance in the coagulation process [107,109,186]. Hemostatic imbalance can be slightly inclined to a hypo- or hypercoagulable status, which explains both the occurrence of hemorrhagic and thrombotic complications [6,111,138]. However, bleeding complications are possible in patients with cirrhosis of the liver, unrelated to haemostatic imbalance, but rather the consequence of portal hypertension or mechanical damage to blood vessels (in variceal bleeding and damage to blood vessels during invasive procedures). Another explanation may be the association of septic conditions, nutritional deficiencies and other comorbidities, which lead to endothelial dysfunction and metabolic impairment, which can lead to disruption of hemostatic and coagulation responses. Factors associated with an increased risk of thrombosis mentioned in the literature include high values of factor VIII (FVIII) and von Willebrand factor (VWF) and low values of protein C, protein S, and antithrombin III [181].

The objectives of the study: To identify the risk factors that lead to thrombotic and hemorrhagic complications in patients with chronic liver diseases hospitalized in Southern Transylvania.

II.4.2. Material and method:

The study is retrospective and is based on the analysis of the electronic database of the Sibiu County Emergency Clinical Hospital. This was made available to us by the hospital's statistical service.

The available data from this source are as follow: name, age, gender, address, biochemical analysis, paraclinical investigations, diagnosis, treatment performed, and medical indications. The study was performed for 3 years, between 1.01.2016 and 31.12.2018 and focused on the data of patients who were admitted to the Gastroenterology, Medical I and II Sections of the Sibiu County Emergency Clinical Hospital.

1396 patients with chronic liver disease (chronic hepatitis and liver cirrhosis of various etiologies and hepatocellular carcinoma) were included in the study, of which 398 patients with chronic liver disease with thrombotic and/or haemorrhagic complications and a control group of 998 consecutive patients with liver disease uncomplicated chronic. The diagnosis of chronic hepatopathy was established based on clinical evidence (laboratory tests and imaging investigations), and thrombotic and hemorrhagic complications were highlighted by abdominal ultrasonography, abdominal computed tomography, and upper digestive endoscopy.

Statistical analysis

Continuous data were presented using the median and interquartile range and their normality was assessed using the Shapiro-Wilk test. Comparisons between groups of independent variables (two or more) were performed with the Mann - Whitney U nonparametric test and the Wilcoxon tests. In the case of categorical data, Chi-square and the Fischer test were used to analyze statistical differences between groups. A p value of 0.05 was considered statistically significant. The regression tree method (CHAID algorithm - Chi-squared Automatic Interaction Detector) was used to identify predictive factors for the study group (compared to the control group). Statistical analyzes and figures were performed using SPSS 21.0 software version (SPSS Inc., Chicago, IL, USA).

II.4.3. Results

The analysis was performed using decision trees (CHAID model), included as predictive variables, which discriminate between the two groups (study vs. control), and the following characteristics (in order of importance): patients in the study group had Ht values smaller compared to those in the control group. Thus, in node 1 of the tree, half of the patients with Ht values $\leq 27\%$ are from the study group. It can also be seen that the number of patients in the study group is decreasing as Ht values increase; in node 2, the Ht values are in the range (27% - 33.8%) we have - witness 67.7% vs. study 32.3% of cases; in node 3, the Ht values are in the range (33.8% - 36.10%) we have - witness 79.7% vs. study 20.3% of cases in node 4, where Ht values are higher than 36.10% we have - control 88.6% vs. study 11.4%. Among patients with Ht $\leq 27\%$, those in the study group had AST values > 67 U / L (those in the study group 70.3% vs. those in the control group 29.7%). Also, some of the patients in the study group had FAS values ≤ 75 U / L (Ht $> 27\%$ and Hb ≤ 9 g / dL and FAS ≤ 75 U / L: study 59.1% vs. control 40.9% compared to Ht $> 27\%$ and Hb ≤ 9 g / dL and FAS > 75 U / L: study 33% vs. control 67%).

II.4.5. Conclusions

1. The most common etiologies of liver diseases were ethanolic - 51.5% (N = 205) and viral - 18.34% (N = 73).
2. Risk factors for the development of thrombotic and hemorrhagic complications, according to the decision trees ' (CHAID model), in our study, were (in order of statistical significance): Ht $< 27\%$, AST > 67 U / L, Hb ≤ 9 mg / dL, FAS ≤ 75 .

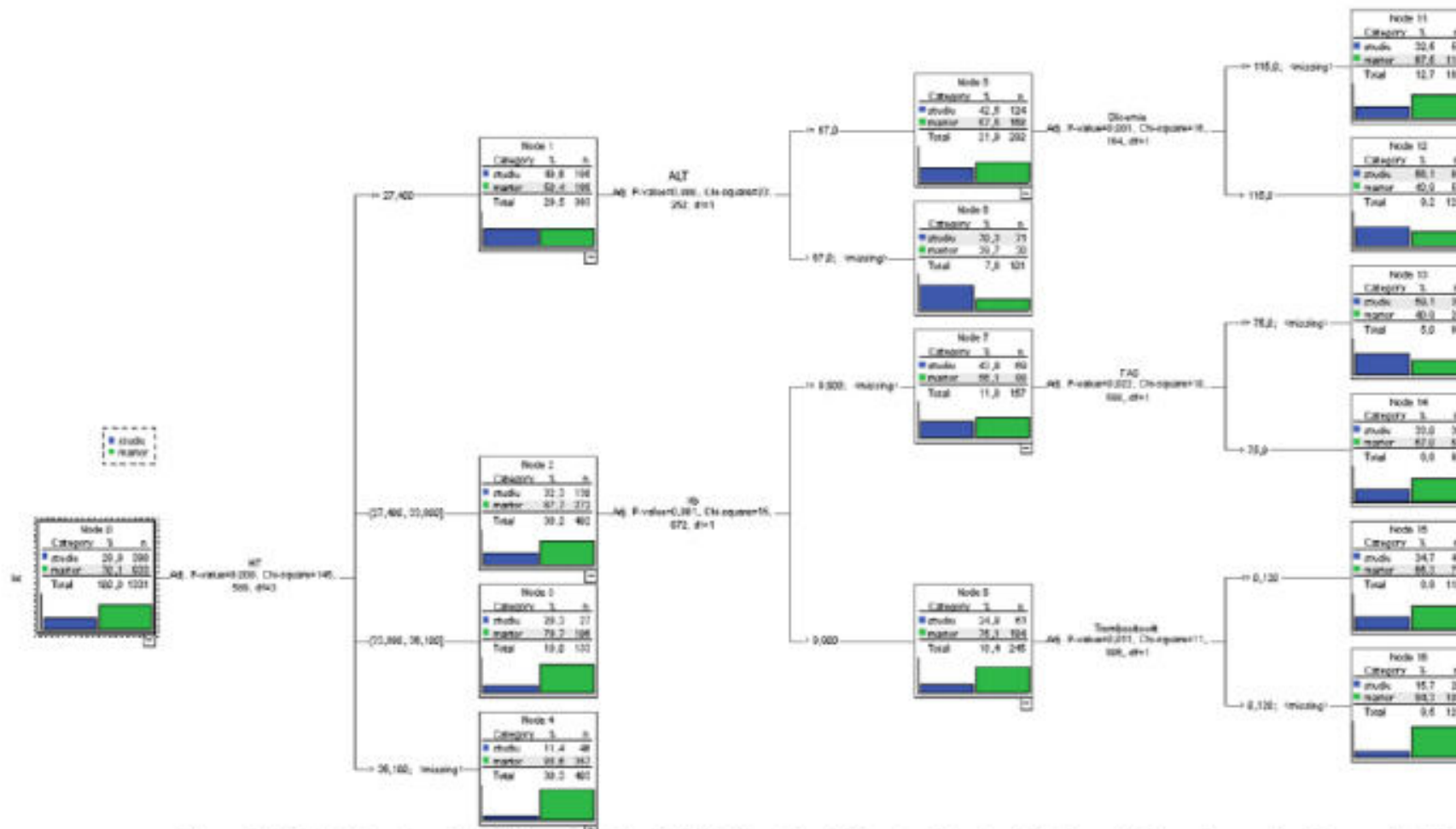

Figure 4.3.7 Decision trees (CHAID model) for highlighting the risk factors involved in thrombotic or hemorrhagic complications

Original elements of the thesis

- It is the first study in the country and in our geographical area in which, using studies of thrombin-poor plasma thrombocytes, thrombotic and hemorrhagic complications were evaluated in patients with chronic liver disease.
- Statistically significant correlations were obtained between thrombin generation parameters and blood cell count parameters, classical tests that explore coagulation and biochemical tests in patients with chronic liver disease.
- Statistically significant results were also obtained from the study of possible correlations between thrombin generation parameters in patients with hepatopathy and hepatic stiffness measured using Fibroscan and estimation of liver fibrosis using noninvasive tests (Forns Index, AST / ALT, APRI and Thrombocytosis).). / long axis of the spleen).
- The importance of noninvasive tests (Forns Index, AST / ALT, APRI and thrombocytes / long spleen) in identifying and assessing the severity of oesophageal varices was highlighted.
- It is the first study that tried to identify and characterize the risk factors involved in the occurrence of thrombotic and hemorrhagic complications in patients with chronic liver disease in Southern Transylvania.
- This paper will be the starting point for future scientific research

GENERAL CONCLUSIONS

1. The study group constituted according to the inclusion and exclusion criteria formulated in the clinical research protocol, included several 59 subjects with chronic hepatopathies, uniformly distributed according to gender [29 men (49.15%) and 30 women (50.85%), $p > 0.05$].
2. Their distribution according to diagnosis was as follows: chronic hepatitis of various etiologies 32% (N = 19) and liver cirrhosis 68% (N = 40) of the selected subjects.
3. The analysis of the recorded data shows that the plasma of patients with chronic liver disease generates less thrombin compared to the control group. In cirrhotic patients, thrombin generation decreases with increasing severity of liver cirrhosis (significantly lower in Child-Pugh C than A). Decreased thrombin generation parameters with increasing severity of liver disease argue for decreased procoagulant potential.
4. Due to the relatively large variability in thrombin generation in patients with chronic liver disease, its dosage could serve as a biomarker for identifying individual haemorrhagic or thrombotic risk; It can also be a useful tool for adapting therapeutic behaviour to the particularities of each patient and for establishing the evolutionary prognosis of the disease.
5. Thrombin generation is also influenced by the aetiology of hepatopathy; patients with hepatopathies of C, ethanolic and mixed viral aetiology had a significantly lower value of the Velocity Index parameter than the control group.
6. There is a statistically significant direct correlation between Ht, PLT and thrombin generation parameters; quantitative and qualitative changes in PLT support their involvement in the pathogenesis of hemostasis in chronic liver diseases.
7. Direct correlations, statistically significant, were also observed after comparing conventional coagulation exploration tests with thrombin generation parameters. However, in liver cirrhosis, conventional coagulation exposure tests are sensitive only to changes induced by abnormalities in the synthesis of coagulation factors and provide little information about anticoagulant factors; therefore, the thrombin generation test is much more useful because it also explores pro- and anticoagulant factors.
8. Statistically significant correlations were also observed between biomarkers of liver dysfunction and thrombin generation parameters; thus, total bilirubinemia and serum alkaline phosphatase are directly correlated with Lag phase and tPeak parameters; this information requires future studies to understand a possible pathogenetic implication.

-
9. The parameters of thrombin generation Peak, VI and ETP are inversely correlated with the following biochemical tests: AST, serum alkaline phosphatase, total bilirubinemia, Bd, albuminemia and serum cholesterolemia. The relationship between total bilirubin and prothrombotic profile could be justified due to the relationship between total bilirubin and the severity of liver dysfunction encountered in liver cirrhosis; and the relationship between serum albumin values and procoagulant status in patients with liver cirrhosis could be based not only on its relationship to the severity of liver cirrhosis but also on the role of albumin in the direct pathophysiology of haemostasis.
 10. Thrombin generation decreases with progression of liver fibrosis (thrombin generation parameters were significantly lower in patients with F4 fibrosis compared to those in F3 subjects).
 11. There are statistically significant correlations between non-invasive tests for estimating liver fibrosis (Forns index, APRI score, AST/ALT, platelet count/spleen long axis score) and thrombin generation parameters.
 12. Statistically significant correlations were also found between non-invasive tests for liver fibrosis and the degree of oesophageal varices, the long axis of the spleen and the diameter of the portal vein in the hilum.
 13. The long axis of the spleen correlates directly with the parameters Lag phase and tPeak and vice versa with the parameters Peak and VI. The same direct correlations were between the VP diameter and the Lag phase and tPeak parameters; VP was inversely correlated with Peak and VI parameters.
 14. Changes in thrombin generation in association with the degree of liver fibrosis during the course of liver cirrhosis may be considered as clinical markers of the transition from compensated to decompensated liver cirrhosis.
 15. Significantly statistically correlations were identified between liver cirrhosis severity scores (MELD, Child Pugh Class) and liver fibrosis progression rate and thrombin generation parameters; the progression of liver cirrhosis, the lower the parameters of thrombin generation; as the rate of progression of liver fibrosis gets higher (the more intense the fibrogenesis), the thrombin generation (reflected in the higher values of Peak, VI and AUC) increases and decreases the latency period until the onset of the process thrombin generation and the maximum value is generated (expressed by Lag phase and tPeak).
 16. Using constantly performed biological tests to monitor and diagnose chronic liver disease, indications for non-invasive assessment of liver fibrosis can be made without
-

-
- the need for additional costs and can improve the medical management of patients with chronic liver disease by limiting endoscopic examination in patients considered at risk, or in hospitals where upper digestive endoscopy is not within easy medical reach.
17. Serological markers can be used as a tool to identify patients with cirrhosis of the liver in whom the clinical risk of complications of esophageal varices is obvious.
 18. Another study aimed to identify the risk factors involved in the occurrence of thrombotic and hemorrhagic complications; the evaluated target population included 398 patients with chronic liver disease [60.71% (N = 241) men and 39.29% (N = 156) women];
 19. The share of patients with chronic liver disease with thrombotic and hemorrhagic complications from urban areas [65.58% (N = 261)] was higher compared to people from rural areas [34.42% (N = 137).)], probably their greater addressability to medical services.
 20. The mortality due to hemorrhagic complications of the patients included in the study was 22.66%; deaths were recorded both in the case of those in critical condition and in the group of those hemodynamically stable.
 21. Patients with chronic liver disease and thrombotic complications had a higher percentage of ascites (51.46%), while hemorrhagic complications were more frequently associated with the presence of grade III esophageal varices (92.63%).
 22. Following the analysis of ultrasound parameters, patients with thrombotic and hemorrhagic complications had a significantly longer spleen long axis ($p = 0.026$), compared to the other two study groups.
 23. The values of AST, ALT, GGT and Bd are significantly higher in the whole group of patients than in the control group; this attests to the progression of liver disease, from compensated to decompensated disease.
 24. The risk factors for the development of thrombotic and haemorrhagic complications, according to the decision trees ' (CHAID model), in order of statistical significance, were: Ht <27%, AST > 67 U / L, Hb <= 9 mg / dL, FAS <= 75 U / L.
 25. Diagnostic, prognostic and evolutionary biomarkers used in chronic liver diseases (platelets, hematocrit, INR, APTT, Bt, Bd, Albuminemia and gammaglobulinemia) are significantly correlated with thrombin generation parameters. As a result, they can also be used to identify the risk of these patients developing bleeding complications induced by the investigated liver pathology; they can also be used to calculate bleeding risk scores in patients with chronic liver disease.
-

26. Diagnostic, prognostic and evolutionary biomarkers used in chronic liver diseases (platelets, hematocrit, INR, APTT, Bt, Bd, Albuminemia and gammaglobulinemia) are significantly correlated with thrombin generation parameters. As a result, they can also be used to identify the risk of these patients developing the bleeding complications induced by the investigated liver pathology; they can also be used to calculate bleeding risk scores in patients with chronic liver disease.

BIBLIOGRAPHY

1. ABERG F, LASSILA R, ILMAKUNNAS M, *et al.* Chronic liver disease and thrombosis risk. *Duodecim*, 2015;131(1):321-330.
2. ALEMPIJEVIC T, BULAT V, DJURANOVIC S, *et al.* Right liver lobe/albumin ratio: contribution to non-invasive assessment of portal hypertension. *World J Gastroenterol*, 2007;13(40):5331-5335.
3. AMITRANO L, BRANCACCIO V, GUARDASCIONE MA, *et al.* Inherited coagulation disorders in cirrhotic patients with portal vein thrombosis. *Hepatology*, 2000;31(2):345-348.
4. ANDRONESCU CI, PURCĂREA M.R, BABEȘ P.A. Nonalcoholic fatty liver disease: Epidemiology, pathogenesis and therapeutic implications. *J. Med. Life* 2018;11(1):20–23.
5. ARGO CK, BALOGUN RA. Blood products, volume control, and renal support in the coagulopathy of liver disease. *Clin Liver Dis*, 2009;13(1):73-85.
6. ASKGAARD G, TOLSTRUP JS, KJAER M.S, *et al.* Number of hospital contacts with alcohol problems predicts later risk of alcoholic liver cirrhosis. *Scand. J. Public Health*, 2018, 1403494818763436. Available online: <https://www.ncbi.nlm.nih.gov/pubmed/?term=.+Number+of+hospital+contacts+with+alcohol+problems+predicts+later+risk+of+alcoholic+liver+cirrhosis> (accessed on 2 November 2018).
7. BAIG WW, NAGARAJA MV, VARMA M, *et al.* Platelet count to spleen diameter ratio for the diagnosis of esophageal varices: Is it feasible?. *Can J Gastroenterol*, 2008;22(10):825-828.
8. BĂLĂCEANU A, Ciroza hepatică și tromboza: termeni contradictorii sau interrelaționați, *Revista Societății Române de Medicină Internă*, 2013;1. <http://www.medicina-interna.ro/articol.php?articol=775&lang=ro>, Accesat : 28.05.2017

-
9. BASILI S, CARNEVALE R, NOCELLA C, *et al.* Serum Albumin Is Inversely Associated With Portal Vein Thrombosis in Cirrhosis. *Hepatol Commun*, 2019;3(4):504-512.
 10. BESSER M, BAGLIN C, LUDDINGTON R, *et al.* High rate of unprovoked recurrent venous thrombosis is associated with high thrombin-generating potential in a prospective cohort study. *J Thromb Haemost*, 2008;6(1): 1720–1725.
 11. BEZERRA JA, BUGGE TH, MELIN-ALDANA H, *et al.* Plasminogen deficiency leads to impaired remodeling after a toxic injury to the liver. *Proc Natl Acad Sci U S A*, 1999;96(26):15143-15148.
 12. BITTO N, LIGUORI E, MURA V. Coagulation, Microenvironment and Liver Fibrosis. *Cells*, 2018;7(1): e85.
 13. BORENSZTAJN K, von der THUSEN JH, PEPPELENBOSCH MP, *et al.* The coagulation factor Xa/protease activated receptor-2 axis in the progression of liver fibrosis: a multifaceted paradigm. *J Cell Mol Med*, 2010;14(1-2):143-153.
 14. BORENSZTAJN KS, von der THUSEN JH, SPEK CA. The role of coagulation in chronic inflammatory disorders: a jack of all trades. *Curr Pharm Des*, 2011;17(1):9-16.
 15. BORSOI VIANA MS, TAKEI K, COLLARILE YAMAGUTI DC, *et al.* . Use of AST platelet ratio index (APRI Score) as an alternative to liver biopsy for treatment indication in chronic hepatitis C. *Ann Hepatol*, 2009;8(1):26-31.
 16. BOS S, van den BOOM B, KAMPHUISEN P.W. *et al* Haemostatic profiles are similar across all aetiologies of cirrhosis. *Thromb. Haemost*, 2019;119(1):246–253.
 17. BRODARD J, CALZAVARINI S, GOTTARDI A, *et al.* Low Sensitivity to Thrombomodulin Correlates with Liver Stiffness in Advanced Chronic Liver Disease. *Blood*, 2019;134(1):4948
 18. CAGIN YF, BILGIC Y, BERBER İ, *et al.* The risk factors of portal vein thrombosis in patients with liver cirrhosis. *Exp Ther Med*, 2019;17(4):3189-3194.
 19. CAHILL PA, REDMOND EM, SITZMANN. Endothelial dysfunction in cirrhosis and portal hypertension. *Pharmacol Ther*, 2001;89(1):273– 293.
 20. CAKIR T, CINGI A, YEGEN C. Coagulation dynamics and platelet functions in obstructive jaundiced patients. *J Gastroenterol Hepatol*, 2009;24(5):748-751.
-

-
21. CALDWELL SH, HOFFMAN M, LISMAN T, *et al.* Coagulation disorders and hemostasis in liver disease: pathophysiology and critical assessment of current management. *Hepatology*, 2006;44(1):1039–1046
 22. CALDWELL S, NORTHUP PG. Bleeding complication with liver biopsy: is it predictable?. *Clin Gastroenterol Hepatol*, 2010;8(10):826-829.
 23. CALVARUSO V, MAIMONE S, GATT A, *et al.* Coagulation and fibrosis in chronic liver disease, *Gut*, 2008;57(12):1722-1727.
 24. CAMERER E, DONG W, COUGHLIN SR. Tissue factor- and factor X-dependent activation of protease-activated receptor 2 by factor VIIa. *Proc Natl Acad Sci U S A*, 2000;97(10):5255-5260.
 25. CERVELLI G, BUONOCORE R, SANCHIS-GOMAR F, *et al.* Low serum bilirubin values are associated with pulmonary embolism in a case-control study. *Clin Chem Lab Med*, 2016;54(8):e229-e230.
 26. CHAIRETI R, RAJANI R, BERGQUIST A, *et al.* Increased thrombin generation in splanchnic vein thrombosis is related to the presence of liver cirrhosis and not to the thrombotic event. *Thromb. Res*, 2014;134(1):455–461.
 27. CHAMBERS RC, LEONI P, BLANC-BRUDE OP, *et al.* Thrombin is a potent inducer of connective tissue growth factor production via proteolytic activation of protease-activated receptor-1. *J Biol Chem*, 2000;275(45):35584-35591.
 28. CHAMBERS RC, SCOTTON CJ. Coagulation cascade proteinases in lung injury and fibrosis. *Proc Am Thorac Soc*, 2012;9(3):96-101.
 29. CHANDAIL VS, KOTWALD SK, KOUL S *et al.* Non-invasive markers for prediction of varices in patients with portal hypertension. *International Journal of Research in Medical Sciences*, 2017;5(3): 1007-1010.
 30. CHANDLER WL, DAWSON KL, RUEGGER MC, *et al.* Patients with cirrhosis show a relative increase in thrombin generation that is correlated with lower antithrombin levels. *Blood Coagul. Fibrinolysis*, 2014; Available online: <https://www.ncbi.nlm.nih.gov/pubmed/?term=Patients+with+cirrhosis+show+a+relative+increase+in+thrombin+generation+that+is+correlated+with+lower+antithrombin+levels.+Blood+Coagul+Fibrinolysis> (accessed on 3 November 2018).
 31. CHEN H, TRILOK G, WANG F, *et al.* A single hospital study on portal vein thrombosis in cirrhotic patients - clinical characteristics & risk factors. *Indian J Med Res*, 2014;139(2):260-266.
 32. CHO EJ, KIM MY, LEE JH, *et al.* Diagnostic and Prognostic Values of Noninvasive Predictors of Portal Hypertension in Patients with Alcoholic Cirrhosis. *PLoS One*, 2015;10(7):e0133935.
-

-
33. CIRINO G, CICALA C, BUCCI MR, *et al.* Thrombin functions as an inflammatory mediator through activation of its receptor. *J Exp Med*, 1996;183(3):821-827.
 34. COUGHLIN SR. Thrombin signalling and protease-activated receptors. *Nature*, 2000;407(6801):258-264
 35. COUGHLIN SR. Protease-activated receptors in hemostasis, thrombosis and vascular biology. *J Thromb Haemost*, 2005;3(8):1800-1814.
 36. CUNNINGHAM MA, RONDEAU E, CHEN X, *et al.* Coughlin SR, Holdsworth SR, Tipping PG. Protease-activated receptor 1 mediates thrombin-dependent, cell-mediated renal inflammation in crescentic glomerulonephritis. *J Exp Med*, 2000;191(3):455-462.
 37. DABBAGH K, LAURENT GJ, McANULTY RJ, *et al.* Thrombin stimulates smooth muscle cell procollagen synthesis and mRNA levels via a PAR-1 mediated mechanism. *Thromb Haemost*, 1998;79(2):405-409.
 38. D'AMICO M, SAMMARCO P, PASTA L. Thrombophilic Genetic Factors PAI-1, MTHFR C677T, V Leiden 506Q, and Prothrombin 20210A in Noncirrhotic Portal Vein Thrombosis and Budd-Chiari Syndrome in a Caucasian Population. *Int J Vasc Med*. 2013;2013(1):717480.
 39. D'ANGELO A, VIGANO -D'ANGELO S, ESMON CT, *et al.* Acquired deficiencies of protein S. Protein S activity during oral anticoagulation, in liver disease, and in disseminated intravascular coagulation. *J Clin Invest*, 1988;81(5):1445-1454.
 40. DAS SK, MUKHERJEE S, VASUDEVAN DM, *et al.* Comparison of haematological parameters in patients with non-alcoholic fatty liver disease and alcoholic liver disease. *Singapore Med J*, 2011;52(3):175-181.
 41. de BOER MT, CHRISTENSEN MC, ASMUSSEN M, *et al.* The impact of intraoperative transfusion of platelets and red blood cells on survival after liver transplantation. *Anesth Analg*, 2008;106(1):32-44.
 42. de FRANCHIS R. Revising consensus in portal hypertension: report of the Baveno V consensus workshop on methodology of diagnosis and therapy in portal hypertension. *J Hepatol*, 2010;53(4):762-768.
 43. De GOTTARDI A, THEVENOT T, SPAHR L, *et al.* Risk of complications after abdominal paracentesis in cirrhotic patients: a prospective study. *Clin Gastroenterol Hepatol*, 2009;7(8):906-909.
 44. de LEDINGHEN V, VERGNIOL J. Transient elastography (FibroScan). *Gastroenterol Clin Biol*, 2008;32(6):58-67.
 45. DEGUQUI H, PECHENIUK NM, ELIAS DJ, *et al.* High-density lipoprotein deficiency and dyslipoproteinemia associated with venous thrombosis in men. *Circulation*, 2005;112(6):893-899.
-

-
46. DEL BEN M, CAPORALE A, FEOLE K, *et al.* Intracranial hemorrhage due to brain metastases in an Italian HCV patient with hepatocellular carcinoma. *J Exp Clin Cancer Res*, 2003;22(4):641-644.
 47. DENG H, QI X, PENG Y, *et al.* Diagnostic Accuracy of APRI, AAR, FIB-4, FI, and King Scores for Diagnosis of Esophageal Varices in Liver Cirrhosis: A Retrospective Study. *Med Sci Monit*, dec. 2015;94(42):3961-3977.
 48. DILLON A, EGAN K, KEVANE B, *et al.* Liver stiffness and thrombin generation in compensated cirrhosis. *Res Pract Thromb Haemost*, Jan. 2019;3(2):291-297.
 49. DINEVARI MF, SOMI M, TARZAMNI M, *et al.* The diagnostic value of non-invasive serum liver fibrosis indices in the prediction of portal hypertension in cirrhotic patients: a cross-sectional study, *J Res Clin Med*, 2020;8(1):23.
 50. DROLZ A, HORVATIS T, ROEDL K, *et al.* Coagulation parameters and major bleeding in critically ill patients with cirrhosis. *Hepatology*, 2016;64(2):556-568.
 51. FARMER AD, SAADEDDIN A, HOŞT CE, *et al.* Portal vein thrombosis in the district general hospital: management and clinical outcomes. *Eur J Gastroenterol Hepatol*, 2009;21(5):517-521
 52. FARRELL DJ, HINES JE, WALLS AF, *et al.* Intrahepatic mast cells in chronic liver diseases. *Hepatology*, 1995;22(4 Pt 1):1175-1181.
 53. FEISTRITZER C, RIEWALD M. Endothelial barrier protection by activated protein C through PAR1-dependent sphingosine 1-phosphate receptor-1 cross activation. *Blood*, 2005;105(8):3178-3184.
 54. FEISTRITZER C, LENTA R, RIEWALD M. Protease-activated receptors-1 and -2 can mediate endothelial barrier protection: role in factor Xa signaling. *J Thromb Haemost*, 2005;3(12):2798-2805.
 55. FERRO D, QUINTARELLI C, LATTUADA A, *et al.* High plasma levels of von Willebrand factor as a marker of endothelial perturbation in cirrhosis: relationship to endotoxemia. *Hepatology*, 1996;23(6):1377-1383.
 56. FIERBINȚEANU C. Evaluarea fibrozei hepatice: rolul biopsiei hepatice și al testelor neinvazive, *Revista de Medicină internă*, 2009;4(1):1-13.
 57. FINKELMEIER F, BETTINGER D, KOBERLE V, *et al.* Single measurement of hemoglobin predicts outcome of HCC patients. *Med Oncol*, 2014;31(1):806.
 58. FIORUCCI S, AANTONELLI E, DISTRUTTI E, *et al.* PAR1 antagonism protects against experimental liver fibrosis. Role of proteinase receptors in stellate cell activation. *Hepatology*, 2004;39(2):365-375.
 59. FISHER NC, MUTIMER DJ. Central venous cannulation in patients with liver disease and coagulopathy--a prospective audit. *Intensive Care Med*, 1999;25(5):481-485.
-

-
60. FONGA-DJIMI HS, GOTTRAND F, BONNEVALLE M, *et al.* A fatal case of portal hypertension complicating systemic mastocytosis in an adolescent. *Eur J Pediatr*, 1995;154(10):819-821.
 61. FOSTER PF, MOORE LR, SANKARY HN, *et al.* Central venous catheterization in patients with coagulopathy. *Arch Surg*, 1992;127(3):273-275.
 62. FOUCHER J, CASTERA L, BERNARD PH, *et al.* Prevalence and factors associated with failure of liver stiffness measurement using FibroScan in a prospective study of 2114 examinations. *Eur J Gastroenterol Hepatol*, 2006;18(4):411-412.
 63. FRIEDMAN SL. Liver fibrosis - from bench to bedside. *J Hepatol*, 2003;38(1):S38-S53.
 64. FRIEDMAN SL. Hepatic stellate cells: protean, multifunctional, and enigmatic cells of the liver. *Physiol Rev*, 2008;88(1):125-172.
 65. GACA MD, ZHOU X, BENYON RC. Regulation of hepatic stellate cell proliferation and collagen synthesis by proteinase-activated receptors. *J Hepatol*, 2002;36(3):362-369.
 66. GAO B, XIAO J, ZHANG M, *et al.* High-density lipoprotein cholesterol for the prediction of mortality in cirrhosis with portal vein thrombosis: a retrospective study. *Lipids Health Dis*, Mar. 2019;18(1):79.
 67. GATT A, RIDDELL A, CALVARUSO V, *et al.* Enhanced thrombin generation in patients with cirrhosis-induced coagulopathy. *J Thromb Haemost*, 2010;8:194-200.
 68. GHADIR MR, RIAHIN AA, HAVASUPAI A, *et al.* The relationship between lipid profile and severity of liver damage in cirrhotic patients. *Hepat Mon*, 2010;10(4):285-288
 69. GHERLAN GS, PETRE IC, Evaluarea noninvazivă a fibrozei, activității inflamatorii și steatozei în Hepatitele cronice virale, Rezumat al tezei de doctorat, 2013, <https://www.cdt-babes.ro/cercetare/evaluare-noninvaziva-fibroza-steatoza-hepatita-cronica-virala-gherlan-george-teza-doctorat.pdf>, Accesat : 05.06.2017
 70. GIANNINI EG, BOTTA F, BORRO P, *et al.* Application of the platelet count/spleen diameter ratio to rule out the presence of oesophageal varices in patients with cirrhosis: a validation study based on follow-up. *Dig Liver Dis*, 2005;37(10):779-785.
 71. GINES P, KAMATH PS, ARROYO V, *et al.* Chronic liver failure: mechanisms and management. New York: Springer, 2011;1(1):289-303, <http://sites.tufts.edu/imlib/wp-content/blogs.dir/1976/files/2014/05/Coagulopathy-of-Chronic-Liver-Disease-NEJM-2011-265-147.pdf>.
 72. GONZALEZ-RAMIREZ E, QUINTERO-PLATT G, MARTIN-GONZALEZ C *et al.* Thrombin activation and liver inflammation in advanced hepatitis C virus infection. *World J Gastroenterol*, 2016;22(18):4427-4437.
-

-
73. GREWALD PK, UCHIYAMA S, DITTO D, *et al.* The Ashwell receptor mitigates the lethal coagulopathy of sepsis. *Nat Med*, 2008;14(6):648-655.
 74. GRIFFIN JH, KOJIMA K, BANKA CL, *et al.* High-density lipoprotein enhancement of anticoagulant activities of plasma protein S and activated protein C. *J Clin Invest*, 1999;103(2):219-227.
 75. GROENEVELD D., PORTE RJ., LISMAN T. Thrombomodulin-modified thrombin generation testing detects a hypercoagulable state in patients with cirrhosis regardless of the exact experimental conditions. *Thrombosis research*, 2014; 134(3): 753-756.
 76. GRONBAEK H, JOHNSEN SP, JEPSEN P, *et al.* Liver cirrhosis, other liver diseases, and risk of hospitalisation for intracerebral haemorrhage: a Danish population-based case-control study. *BMC Gastroenterol*, 2008;8(1):16.
 77. HAERI NS, LINN S, BUTLER T *et al.* Non-Invasive Predictors of Esophageal Varices in Cirrhosis Patients, *American Journal of Gastroenterology*, 2017 ;112(1) : p S564.
 78. HAMUR H, DUMAN H, BAKIRCI EM, *et al.* Bilirubin Levels and Thrombus Burden in Patients With ST-Segment Elevation Myocardial Infarction. *Angiology*, 2016;67(6):565-570.
 79. HEDERSON NC, IREDALE JP. Liver fibrosis: cellular mechanisms of progression and resolution. *Clin Sci (Lond)*, 2007;112(5):265-280.
 80. HILLEBRANDT S, WASMUTH H, WEISKIRCHEN R. *et al.* Complement factor 5 is a quantitative trait gene that modifies liver fibrogenesis in mice and humans. *Nat Genet*, 2005;37(1):835–843.
 81. HOLLESTELLE MJ, GEERTZEN HG, STRAATSBURG IH, *et al.* Factor VIII expression in liver disease. *Thromb Haemost*, 2004;91(2):267-275.
 82. HOU MC, LIN HC, LIU TT, *et al.* Antibiotic prophylaxis after endoscopic therapy prevents rebleeding in acute variceal hemorrhage: a randomized trial. *Hepatology*, 2004;39(3):746-753.
 83. HRON G, KOLLARS M, BINDER BR, *et al.* Identification of patients at low risk for recurrent venous thromboembolism by measuring thrombin generation. *JAMA*, 2006;296(4):397-402.
 84. HSIEH MJ, LU CH, TSAI NW, *et al.* Prediction, clinical characteristics and prognosis of intracerebral hemorrhage in hepatocellular carcinoma patients with intracerebral metastasis. *J Clin Neurosci*, 2009;16(3):394-398.
 85. HUANG HH, LIN HH, SHIH YL, *et al.* Spontaneous intracranial hemorrhage in cirrhotic patients. *Clin Neurol Neurosurg*, 2008;110(3):253-258.
 86. HUSSEIN HA, TAMER W, SALAHDELDIN M, *et al.* AST/ALT Ratio for detection and severity classification of Esophageal Varices in Child A HCV Liver cirrhosis Egyptian Patients. *Life Science Journal*, 2015;12(4):12-17.
-

-
87. INTAGLIATA NM, NORTHUP PG. Anticoagulant Therapy in Patients with Cirrhosis. *Seminars in thrombosis and hemostasis*, 2015;41(5):514-519.
 88. INTAGLIATA NM, ARGO CK, STINE JG, *et al.* Concepts and controversies in haemostasis and thrombosis associated with liver disease. In *Proceedings of the 7th International Coagulation in Liver Disease Conference*, Rome, Italy, 6–7 October 2017.
 89. IREDALE JP. Models of liver fibrosis: exploring the dynamic nature of inflammation and repair in a solid organ. *J Clin Invest*, 2007;117(3):539-548.
 90. IWAKIRI Y, GROSZMANN RJ. Vascular endothelial dysfunction in cirrhosis. *Journal of Hepatology*, 2007;46(5):927-934.
 91. IWAKIRI Y. “Endothelial dysfunction in the regulation of cirrhosis and portal hypertension.” *Liver international : official journal of the International Association for the Study of the Liver*, 2012;32(2):199-213.
 92. JALAN R. *Clinical Practice Guidelines: Vascular diseases of the liver*, European Association for the Study of the Liver, 2016;64(1):179-202.
 93. KALAFATELI M, GURUSAMY KS, NOEL-STORR AH, *et al.* Forns index and 'FIB4' for staging of fibrosis in adults with chronic hepatitis C. *Cochrane Database of Systematic Reviews*, 2015;11(1): CD011929.
 94. KALAMBOSKIS GN, OIKONOMOUA, BALTAYIANNIS G, *et al.* Thrombin generation measured as thrombin-antithrombin complexes predicts clinical outcomes in patients with cirrhosis. *Hepatology research : the official journal of the Japan Society of Hepatology*, 2016;46(3): E36-44.
 95. KREMERS RMW, KLEINEGRIS M-C, NINIVAGGI M, *et al.* Decreased prothrombin conversion and reduced thrombin inactivation explain rebalanced thrombin generation in liver cirrhosis. *PLoS ONE*, 2017;12(5): e0177020.
 96. KUJOVICH JL. Coagulopathy in liver disease: A balancing act. *Hematol. Am. Soc. Hematol. Educ, Program* 2015;1(1):243–249.
 97. KUMAR SDL, SUDARSI B, SIDDESWARI R, *et al.* Correlation of Portal Vein Size with Esophageal Varices Severity in Patients with Cirrhosis of Liver with Portal Hypertension *JAPI*, 2003;5(1).
 98. KUROE K, KUROKAWA T, NISHIKIMI M, *et al.* Effects of thromboxane A2 synthetase inhibitor on postischemic liver injury in rats. *Eur Surg Res*, 1991;23(1):20-26.
 99. KYRIAKOU D, KOUROUMALIS E, KONSOLAS J, *et al.* Systemic mastocytosis: a rare cause of noncirrhotic portal hypertension simulating autoimmune cholangitis--report of four cases. *Am J Gastroenterol*, 1998;93(1):106-108.
-

-
100. LEBRETON A, SINEGRE T, PEREIRA B, *et al.* Plasma hypercoagulability in the presence of thrombomodulin but not of activated protein C in patients with cirrhosis. *J. Gastroenterol. Hepatol*, 2017;32(4):916–924.
101. LEBRETON A, SINEGRE T, LECOMPTE T, *et al.* Thrombin Generation and Cirrhosis: State of the Art and Perspectives. *Semin. Thromb. Hemost*, 2020;46(6):693–703.
102. LEE HJ, HINRICHS CR. Is coagulopathic liver disease a factor in spontaneous cerebral hemorrhage?. *J Comput Assist Tomogr*, 2002;26(1):69-72.
103. LEVY GA, MACPHEE PJ, FUNG LS, *et al.* The effect of mouse hepatitis virus infection on the microcirculation of the liver. *Hepatology*, 2003;3(6):964-973.
104. LI B, ZHANG C, ZHAN YT. Nonalcoholic Fatty Liver Disease Cirrhosis: A Review of Its Epidemiology, Risk Factors, Clinical Presentation, Diagnosis, Management, and Prognosis. *Can J. Gastroenterol. Hepatol*, 2018;550(1):1-8.
105. LI J, QI X, DENG H, *et al.* Association of conventional haemostasis and coagulation tests with the risk of acute upper gastrointestinal bleeding in liver cirrhosis: a retrospective study. *Gastroenterol Rep*, 2016;4(4):315-319.
106. LIAO WC, HOU MC, CHANG CJ, *et al.* Potential precipitating factors of esophageal variceal bleeding: a case-control study. *Am J Gastroenterol*, 2011;106(1):96-103.
107. LISMAN T, LEEBEEK FW, de GROOT PG. Haemostatic abnormalities in patients with liver disease. *J Hepatol*, 2002;37(2):280-287.
108. LISMAN T, ADELMEIJER J, de GROOT PG, *et al.* No evidence for an intrinsic platelet defect in patients with liver cirrhosis – studies under flow conditions. *J Thromb Haemost*, 2006;4(9):2070-2072.
109. LISMAN T, CALDWELL SH, LEEBEEK FW, *et al.* Is chronic liver disease associated with a bleeding diathesis? *J Thromb Haemost*, 2006;4(1):2059–2060.
110. LISMAN T, LEEBEEK FW. Hemostatic alterations in liver disease: a review on pathophysiology, clinical consequences, and treatment. *Dig Surg*, 2007;24(4):250-258.
111. LISMAN T, CALDWELL SH, BURROUGHS AK, *et al.* Hemostasis and thrombosis in patients with liver disease: the ups and downs. *J Hepatol*, 2010;53(2):362-371.
112. LISMAN T, PORTE RJ. Rebalanced hemostasis in patients with liver disease: evidence and clinical consequences. *Blood*. 2010;116(6):878-885.
113. LISMAN T, CALDWELL SH, PORTE RJ. Anemia as a potential contributor to bleeding in patients with liver disease – Neglected but not forgotten. *Journal of Hepatology*, 2011;54(3):594–595.
-

-
114. LISMAN T, BAKHTIARI K, ADELMEIJER J, *et al.* Intact thrombin generation and decreased fibrinolytic capacity in patients with acute liver injury or acute liver failure. *J Thromb Haemost*, 2012;10(7):1312-1319.
115. LISMAN T, PORTE RJ. Pathogenesis, prevention, and management of bleeding and thrombosis in patients with liver diseases. *Res Pract Thromb Haemost*, 2017;1(2):150-161.
116. MACCALLUM PK, COOPER JA, MARTIN J, *et al.* Haemostatic and lipid determinants of prothrombin fragment F1.2 and D-dimer in plasma. *Thromb Haemost*, 2000;83(3):421-426.
117. MADHOTRA R, MULCAHY HEI, WILLNER I, *et al.* Prediction of esophageal varices in patients with cirrhosis. *J Clin Gastroenterol*, 2002;34(1):81-85.
118. MAHAL AS, KNAUER CM, GREGORY PB. Bleeding after liver biopsy. *West J Med*, 1981;134(1):11-14.
119. MALDONADO LOPEZ CJ, JIMENEZ SAAB NG, SANCHEZ HERNANDEZ. Hipoalbuminemia como factor de riesgo para hemorragia del tubo digestivo *Child B, Med Int Mex*, 2012;28(4):319-324.
120. MANZANO-ROBLEDA MDC, BARRANCO-FRAGOSO B, URIBE M *et al.* Portal vein thrombosis: what is new?. *Annals of hepatology*, 2015;14(1):20-27.
121. MARRA F, GRANDALIANO G, VALENTE AJ, *et al.* Thrombin stimulates proliferation of liver fat-storing cells and expression of monocyte chemoattractant protein-1: potential role in liver injury. *Hepatology*, 1995;22(3):780-787.
122. MARRA F, DeFRANCO R, GRAPPONE C, *et al.* Expression of the thrombin receptor in human liver: up-regulation during acute and chronic injury. *Hepatology*, 1998;27(2):462-471.
123. MCGIBBON A, CHEN GI, PELTEKIAN KM, *et al.* An evidence-based manual for abdominal paracentesis. *Dig Dis Sci*, 2007;52(12):3307-3315.
124. McLAUGHLIN JN, SHEN L, HOLINSTAT M, *et al.* Functional selectivity of G protein signaling by agonist peptides and thrombin for the protease-activated receptor-1. *J Biol Chem*, 2005;280(26):25048-25059.
125. McVAY PA, TOY PT. Lack of increased bleeding after liver biopsy in patients with mild hemostatic abnormalities. *Am J Clin Pathol*, 1990;94(6):747-753.
126. McVAY PA, TOY PT. Lack of increased bleeding after paracentesis and thoracentesis in patients with mild coagulation abnormalities. *Transfusion*, 1991;31(2):164-171.
127. MERCER PF, CHAMBERS RC. Coagulation and coagulation signalling in fibrosis. *Biochim Biophys Acta*, 2013;1832(7):1018-1027.
-

-
- 128.MERKEL C, ZOLI M, SIRINGO S, *et al.* Prognostic indicators of risk for first variceal bleeding in cirrhosis: a multicenter study in 711 patients to validate and improve the North Italian Endoscopic Club (NIEC) index. *Am J Gastroenterol.* 2000;95(10):2915-2920.
- 129.MIHĂILĂ RG, NEDELCU, FRĂȚILĂ O. *et al.* Lovastatin and fluvastatin reduce viremia and the pro-inflammatory cytokines in the patients with chronic hepatitis C. *HepatoGastroenterology*, 2009;56(96):1710-1713.
- 130.MIHĂILĂ RG. Provocări și soluții în Medicina Internă de astăzi, 2014, <http://doctorate.ulbsibiu.ro/obj/documents/RezumatRomana-Mihaila-Romeo.pdf>, Accesat: 07.06.2016
- 131.MIHĂILĂ RG, DRAGOMIR I. Advances of knowledge on coagulation disorders in liver cirrhosis and their clinical consequences, *Biomedical Research*, 2015;26(4):625-632.
- 132.MILLAN JL. Alkaline Phosphatases : Structure, substrate specificity and functional relatedness to other members of a large superfamily of enzymes. *Purinergic Signal*, 2006;2(2):335-341.
- 133.MULLER F, MUTCH NJ, SCHENK WA, *et al.* Platelet polyphosphates are proinflammatory and procoagulant mediators in vivo. *Cell*, 2009;139(6):1143-1156.
- 134.NG VL, SABLA GE, MELIN-ALDANA H, *et al.* Plasminogen deficiency results in poor clearance of non-fibrin matrix and persistent activation of hepatic stellate cells after an acute injury. *J Hepatol*, 2001;35(6):781-789.
- 135.NICHOLLS SJ, CUTRI B, WORTHLEY SG, *et al.* Impact of short-term administration of high-density lipoproteins and atorvastatin on atherosclerosis in rabbits. *Arterioscler Thromb Vasc Biol*, 2005;25(11):2416-2421.
- 136.NOROHA FERREIRA C, SEIJO S, *et al.* Natural history and management of esophagogastric varices in chronic noncirrhotic, nontumoral portal vein thrombosis. *Hepatology*, 2016;63(5):1640-1650.
- 137.NORTHUP PG, McMAHON MM, RUHL AP, *et al.* Coagulopathy does not fully protect hospitalized cirrhosis patients from peripheral venous thromboembolism. *Am J Gastroenterol*, 2006;101(7):1524-1680.
- 138.NORTHUP P G, SUNDARAM V, FALLON MB, *et al.* Hypercoagulation and thrombophilia in liver disease. *Journal of thrombosis and haemostasis*, 2008;6(1): 2-9.
- 139.O'DONNELL J, MUMFORD AD, MANNING RA, *et al.* Marked elevation of thrombin generation in patients with elevated FVIII:C and venous thromboembolism. *Br J Haematol*, 2001;115(3):687-691.
140. OKUDA K, OHNISHI K, KIMURA K, *et al.* Incidence of portal vein thrombosis in liver cirrhosis. An angiographic study in 708 patients. *Gastroenterology*, 1985;89(2):279-286.
141. OLTEANU AL, MIHALACHE M. MIHĂILĂ RG. Global test of haemostasis: Thrombin generation assay. *Acta Med. Transilv.* 2015;20(4):135–138.
-

-
142. OLTEANU AL, MIHĂILĂ RG, MIHALACHE M. Evaluation of thrombin generation in classical Philadelphia-negative myeloproliferative neoplasms. *Rev. Romana Med. Lab*, 2016;24(3): 279–289.
143. OSLAKOVIC C, KRISINGER MJ, ANDERSSON A, *et al.* Anionic phospholipids lose their procoagulant properties when incorporated into high density lipoproteins. *J Biol Chem*, 2009;284(9):5896-5904.
144. OSLAKOVIC C, JAUHAINEN M, EHNHOLM C, *et al.* The role of phospholipid transfer protein in lipoprotein-mediated neutralization of the procoagulant effect of anionic liposomes. *J Thromb Haemost*, 2010;8(4):766-772.
145. PACHE I, BILODEAU M. Severe haemorrhage following abdominal paracentesis for ascites in patients with liver disease. *Aliment Pharmacol Ther*, 2005;21(5):525-529.
146. PAPTODORIDIS GV, PAKONSTANTINOEU E, ANDRIOTI E, *et al.* Thrombotic risk factors and extent of liver fibrosis in chronic viral hepatitis. *Gut*, 2003;52(3):404-409.
147. PAVLOV CS, CASAZZA G, NIKOLOVA D, *et al.* Transient elastography for diagnosis of stages of hepatic fibrosis and cirrhosis in people with alcoholic liver disease. *Cochrane Database Syst Rev*, 2015;1(1):CD010542
148. PECK-RADOSAVLJEVIC M. Thrombocytopenia in liver disease. *Can J Gastroenterol*, 2000;14(D):60D-66D.
149. PENG GS, YIN SJ, CHENG CA, *et al.* Increased risk of cerebral hemorrhage in Chinese male heavy drinkers with mild liver disorder. *Cerebrovasc Dis*, 2007;23(4):309-314.
150. PENZ-ÖSTERREICHER M, ÖSTERREICHER CH, TRAUMER M. Fibrosis in autoimmune and cholestatic liver disease. *Best Pract Res Clin Gastroenterol*, 2011;25(2):245-258.
151. PIKE AF, KRAMER NI, BLAAUBOER BJ, *et al.* A novel hypothesis for an alkaline phosphatase 'rescue' mechanism in the hepatic acute phase immune response. *Biochim Biophys Acta*, 2013;1832(12):2044-2056.
152. PIMPIN L, CORTEZ-PINTO H, NEGRO F *et al.* Burden of liver disease in Europe: Epidemiology and analysis of risk factors to identify prevention policies. *J. Hepatol*, EASL HEPHEALTH Steering Committee, 2018;69(1): 718–735.
153. PINZANI M, ROMBOUTS K. Liver fibrosis: from the bench to clinical targets published correction appears in *Dig Liver Dis*, 2004;36(8):562-563.
154. POPESCU I. *Chirurgia Ficatului*, Editura universală Carol Davila, București, 2004;1(1):745-792.
155. POSOIU C.R., Fibroza hepatica din bolile hepatice cronice si investigarea ei cu ajutorul unui test sigur si simplu: Fibroscan, *Gastroenterologie*, 2012.
-

-
- 156.POTZE W, ARSHAD F, ADELMEIJER J, *et al.* Differential in vitro inhibition of thrombin generation by anticoagulant drugs in plasma from patients with cirrhosis. PLoS One, 2014;9(2):e88390.
- 157.POTZE W, ALKOZAI EM, ADELMEIJER J,*et al.* Hypercoagulability following major partial liver resection – detected by thrombomodulin-modified thrombin generation testing. Aliment. Pharmacol. Ther, 2015;41(1):189-198.
- 158.POTZE W, ADELMEIJER J, PORTE RJ *et al.* Preserved clot formation detected by the Thrombodynamics analyzer in patients with cirrhosis. Thromb. Res, 2015;135(1): 1012-1016 .
- 159.RAMACHANDRAN R, NOORBAKHSH F, DEFEA K, *et al.* Targeting proteinase-activated receptors: therapeutic potential and challenges. Nat Rev Drug Discov, 2012;11(1):69-86.
- 160.RAUTOU PM, TATSUMI K, ANTONIAK S *et al.* Hepatocyte Tissue Factor Contributes to the Hypercoagulable State in a Mouse Model of Chronic Liver Injury. J Hepatology, 2016; 64(1):53-59.
161. RIEWALD M, RUF W. Mechanistic coupling of protease signaling and initiation of coagulation by tissue factor. Proc Natl Acad Sci U S A, 2001;98(14):7742-7747.
162. ROBERTS LN, PATEL RK, ARYA R. Haemostasis and thrombosis in liver disease. British Journal of Haematology, 2010;148(1):507-521.
- 163.ROBERTS LN, WILLIAM B. Management of Bleeding and Thrombosis in Critically Ill Patients with Liver Disease. Seminars in thrombosis and hemostasis, 2015; 41(5):520-526.
- 164.SAJA MF, ABDO AA, SANAI FM, *et al.* The coagulopathy of liver disease: does vitamin K help?. Blood Coagul Fibrinolysis, 2013;24(1):10-17.
- 165.SALIOLA M, LORENZET R, FERRO D, *et al.* Enhanced expression of monocyte tissue factor in patients with liver cirrhosis. Gut, 1998;43(3):428-432.
- 166.SALVAGO GL, FAVALORO EJ, DEMONTE D, *et al.* Influence of hypertriglyceridemia, hyperbilirubinemia and hemolysis on thrombin generation in human plasma. Clin Chem Lab Med, 2019;57(11):1784-1789.
- 167.SARAY A, MESIHOVIC R, VANIS N, *et al.* Protein C Deficiency in Chronic Hepatitis C: Correlation With Histological Extent of Liver Fibrosis.” Clinical and applied thrombosis/hemostasis : official journal of the International Academy of Clinical and Applied Thrombosis/Hemostasis, 2017;23(1):72-77.
- 168.SARIN SK, LAHOTI D. Management of gastric varices. Baillieres Clin Gastroenterol, 1992;6(3):527-548.
- 169.SCHWARTZ LB, IRANI AM, ROLLER K, *et al.* Quantitation of histamine, tryptase, and chymase in dispersed human T and TC mast cells. J Immunol, 1987;138(8):2611-2615.
-

-
170. SEBASTIANI G, TEMPESTA D, FATTOVICH G, *et al.* Prediction of oesophageal varices in hepatic cirrhosis by simple serum non-invasive markers: Results of a multicenter, large-scale study. *J Hepatol*, 2010;53(4):630-638.
171. SEEFF LB, EERSON GT, MORGAN TR, *et al.* Complication rate of percutaneous liver biopsies among persons with advanced chronic liver disease in the HALT-C trial. *Clin Gastroenterol Hepatol*, 2010;8(10):877-883.
172. SEGAL JB, DZIK WH; Transfusion Medicine/Hemostasis Clinical Trials Network. Paucity of studies to support that abnormal coagulation test results predict bleeding in the setting of invasive procedures: an evidence-based review. *Transfusion*, 2005;45(9):1413-1425.
173. SHARARA AI, ROCKEY DC. Gastroesophageal variceal hemorrhage. *N Engl J Med*. 2001;345(9):669-681.
174. SHIMITSU H, PHUONG V, MAIA M, *et al.* Bariatric surgery in patients with liver cirrhosis. *Surg Obesity Relat Dis*, 2013;9(1):1-6.
175. SINEGRE T, DURON C, LECOMPTE T *et al.* Increased factor VIII plays a significant role in plasma hypercoagulability phenotype of patients with cirrhosis. *J. Thromb. Haemost*, 2018;16(1):1132-1140.
176. SINGH S, FUJII LL, MURAD MH, *et al.* Liver stiffness is associated with risk of decompensation, liver cancer, and death in patients with chronic liver diseases: a systematic review and meta-analysis. *Clin Gastroenterol Hepatol*, 2013;11(12):1573-1589.
177. SIREGAR RA, DAIRI LB, SIREGAR GA. Forns index as a useful noninvasive predictor of esophageal varices in liver cirrhosis. *Universa Medicina*, 2016;35(3):199-205.
178. SOGAARD KK, HORVAT-PUHO E, GRONBAEK H, *et al.* Risk of venous thromboembolism in patients with liver disease: a nationwide population-based case-control study. *Am J Gastroenterol*, 2009;104(1):96-101.
179. SOH UJ, DORES MR, CHEN B, *et al.* Signal transduction by protease-activated receptors. *Br J Pharmacol*, 2010;160(2):191-203.
180. SOHAIL, S, MUSTAFA MI, SHAHEEN MA, *et al.* Dyslipidemia and mean lipid profile in patients with liver cirrhosis. *International Journal of Research in Medical Sciences*, 2020;8(5): 1658-1661.
181. THOMAS C. Chapter 105 - Bleeding Risks with Liver Disease, *Transfusion Medicine and Hemostasis*, Academic Press, 2009;2(1)565-569.
182. THOMOPOULOS KC, LABROPOULOU-KARATZA C, MIMIDIS KP, *et al.* Non-invasive predictors of the presence of large oesophageal varices in patients with cirrhosis. *Dig Liver Dis*, 2003;35(7):473-478.
-

-
183. TREJO J, CONNOLLY AJ, COUGHLIN SR. The cloned thrombin receptor is necessary and sufficient for activation of mitogen-activated protein kinase and mitogenesis in mouse lung fibroblasts. Loss of responses in fibroblasts from receptor knockout mice. *J Biol Chem*, 1996;271(35):21536-21541.
184. TRIPODI A, SALERNO F, CHANTARANGKUL V, *et al.* Evidence of normal thrombin generation in cirrhosis despite abnormal conventional coagulation tests. *Hepatology*, (Baltimore, MD) 2005;41(1):553–558.
185. TRIPODI A, PRIMIGNANI M, CHANTARANGKUL V, *et al.* Thrombin Generation in Patients With Cirrhosis: The Role of Platelets. *Hepatology*, 2006;44(1):440–445.
186. TRIPODI A, MANNUCCI PM. Abnormalities of hemostasis in chronic liver disease. Reappraisal of their clinical significance and need for clinical and laboratory research. *J Hepatol*, 2007; 46(1):727–733.
187. TRIPODI A, LEGNANI C, CHANTARANGKUL V, *et al.* High thrombin generation measured in the presence of thrombomodulin is associated with an increased risk of recurrent venous thromboembolism. *J Thromb Haemost*, 2008;6(1):1327–1333.
188. TRIPODI A, PRIMIGNANI M, CHANTARANGKUL V, *et al.* An imbalance of pro- vs anti-coagulation factors in plasma from patients with cirrhosis. *Gastroenterology*, 2009;137(6):2105-2111.
189. TRIPODI A, PRIMIGNANI M, LEMMA L, *et al.* Detection of the imbalance of procoagulant versus anticoagulant factors in cirrhosis by a simple laboratory method. *Hepatology*, 2010;52(1):249-255.
190. TRIPODI A, PRIMIGNANI M, MANNUCCI PM. Abnormalities of hemostasis and bleeding in chronic liver disease. The paradigm is challenged. *Intern Emerg Med*, 2010;5(1):7–12
191. TRIPODI A, MANNUCCI PM. The coagulopathy of chronic liver disease. *The New England journal of medicine*, 2011;365(2):147-156.
192. TRIPODI A, CHANTARANGKUL V, PRIMIGNANI M, *et al.* Thrombin generation in plasma from patients with cirrhosis supplemented with normal plasma: considerations on the efficacy of treatment with fresh-frozen plasma. *Intern Emerg Med*, 2012;7(2):139-144.
193. TRIPODI A., PRIMIGNANI M, LEMMA, *et al.* Evidence that low protein C contributes to the procoagulant imbalance in cirrhosis. *Journal of hepatology*, 2013;59(1): 265-270.
194. TRIPODI A. Hemostasis in Acute and Chronic Liver Disease. *Semin Liver Dis*, 2017;37(1):28-32.
195. TUFANO A, GUIDA A, DIMINNO MN, *et al.*, Prevention of venous thromboembolism in medical patients with thrombocytopenia or with platelet dysfunction: a review of the literature, *Seminars in thrombosis and hemostasis*, 2011;37(3):267-274.
196. VALLA D.C. Thrombosis and anticoagulation in liver disease. *Hepatology*, 2008;47(1): 1384-1393.
-

-
- 197.van VEEN JJ, GATT A, MAKRIS M. Thrombin generation testing in routine clinical practice: are we there yet? *Br J Haematol*, 2008;142(1): 889–903.
- 198.VECERZAN L, CIPĂIAN C, BOICEAN A, *et al.* A portal vein thrombosis and duodenal tumor in a patient with multicentric hepatocellular carcinoma. Case report, *Acta Medica Transilvanica*, 2019;24(1):37-39.
- 199.VECERZAN L, BOICEAN A, CIPĂIAN C, *et al.* The correlation between conventional coagulation tests and the study of thrombin generation in patients with liver cirrhosis, *Acta Medica Transilvanica*, 2019;24(2):31-33.
- 200.VECERZAN L, MIHĂILĂ RG. Risk factors regarding portal vein thrombosis in chronic liver disease, *Acta Medica Transilvanica*, 2020;25(4):38-41
- 201.VECERZAN L, OLTEANU A, MANIU I, *et al.* Thrombin Generation in Chronic Liver Diseases-A Pilot Study. *Healthcare*. 2021;9(5):550.
202. VIEIRA da ROCHA EC, D'AMICO EA, CALDWELL SH, *et al.* A prospective study of conventional and expanded coagulation indices in predicting ulcer bleeding after variceal band ligation. *Clin Gastroenterol Hepatol*, 2009;7(9):988-993.
- 203.VINCENT MA, MONTAGNANI M, QUON MJ. Molecular and physiologic actions of insulin related to production of nitric oxide in vascular endothelium. *Curr Diab Rep*, 2003;3(4):279-288.
- 204.VIOLI F, FERRO D, BASILI S, *et al.* Hyperfibrinolysis increases the risk of gastrointestinal hemorrhage in patients with advanced cirrhosis. *Hepatology*, 1992;15(4):672-676.
- 205.VIOLI F, FERRO D, BASILI S, *et al.* Association between low-grade disseminated intravascular coagulation and endotoxemia in patients with liver cirrhosis. *Gastroenterology*, 1995;109(2):531-539.
- 206.VIOLI F, FERRO D, BASILI S, *et al.* Ongoing prothrombotic state in the portal circulation of cirrhotic patients. *Thromb Haemost*, 1997;77(1):44-47.
- 207.von MONTFORT C, BEIER JI, KAISER JP, *et al.* PAI-1 plays a protective role in CCl4-induced hepatic fibrosis in mice: role of hepatocyte division. *Am J Physiol Gastrointest Liver Physiol*, 2010;298(5):G657-G666.
208. WAN J, ROBERTS LN, HENDRIX W, *et al.* Whole blood thrombin generation profiles of patients with cirrhosis explored with a near patient assay. *J Thromb Haemost*, 2020;18(4):834-843.
209. WANLESS IR, WONG F, BLENDIS LM, *et al.* Hepatic and portal vein thrombosis in cirrhosis: possible role in development of parenchymal extinction and portal hypertension. *Hepatology*, 1995;21(5):1238-1247.
-

-
210. WION KL, KELLY D, SUMMERFIELD JA, *et al.* Distribution of factor VIII mRNA and antigen in human liver and other tissues. *Nature*, 1985;317(6039):726-729.
211. YANG CH, CHIU YC, CHEN CH, *et al.* Diabetes mellitus is associated with gastroesophageal variceal bleeding in cirrhotic patients. *Kaohsiung J Med Sci*, 2014;30(10):515-520.
212. YANG ZJ, SHETH SH, SMITH CH, *et al.* Plasma from chronic liver disease subjects exhibit differential ability to generate thrombin. *Blood Coagulation & Fibrinolysis : an International Journal in Haemostasis and Thrombosis*, 2015;26(7):844-847.
213. YOUNGWON N, KIM JE, LIM HS, *et al.* Coagulation proteins influencing global coagulation assays in cirrhosis: hypercoagulability in cirrhosis assessed by thrombomodulin-induced thrombin generation assay. *BioMed research international*, 2013;1(1):856754.
214. ZERMATTEN MG, FRAGA M, CALDERARA DB, *et al.* Biomarkers of liver dysfunction correlate with a prothrombotic and not with a prohaemorrhagic profile in patients with cirrhosis. *JHEP Rep*, 2020;2(4):100120.
215. ZIOL M, HANDRA-LUCA A, KETTANEH A, *et al.* Noninvasive assessment of liver fibrosis by measurement of stiffness in patients with chronic hepatitis C. *Hepatology*, 2005;41(1):48-54.
216. MA, Di STASIO E, De CRISTOFARO R, *et al.* Thrombotic risk factors in patients with liver cirrhosis: correlation with MELD scoring system and portal vein thrombosis development. *J Hepatol*, 2009;51(4):682-689.
217. MDCalc. Child-Pugh Score for Cirrhosis Mortality, Estimates cirrhosis severity. <https://www.mdcalc.com/child-pugh-score-cirrhosis-mortality>
218. ClinicalTrials.gov, U.S. National Library of Medicine. <https://clinicaltrials.gov/ct2/show/NCT00180674?id=NCT04622449+OR+NCT00180674&draw=2&rank=2&load=cart>
-

